

## Gel Seal Style HEPA or ULPA Filter Replaceable From Roomside

GS Terminal Diffusers are ideal for pharmaceutical companies, manufacturers of medical devices and companies in highly regulated industries. The GS series feature a gel channel on the upstream side of the final filter which provides a leak-free seal between the filter and the housing.

GS Terminal Diffusers feature a HEPA or ULPA filter replaceable from roomside while the filter housing remains in place.

The white powdercoated housing, fabricated from 20 gauge steel, is positively sealed to a hood fabricated from galvanized steel.

A 10" or 12" diameter inlet collar at the center of the filter hood allows for simple field connection to the main air supply using flexible duct.

The damper assembly is adjustable from within the room and is supported by a damper support channel permanently attached to the filter hood duct collar. A perforated damper disc is mounted on threaded rod and a guide provides screwdriver adjustments of the damper assembly from roomside.

Final filters are protected with a white epoxy diamond pattern grille and are tested according to accepted procedures as described by the Institute of Environmental Sciences (IEST) and/or ISO standards. The standard HEPA filter is 99.99% eff. and an ULPA grade 99.9995% eff. filter is available as an option.

A polystyrene eggcrate grille in an anodized aluminum frame is hinged to open, permitting removal of the filter without removing the unit from the ceiling. Optional perforated stainless steel or aluminum grilles are available.



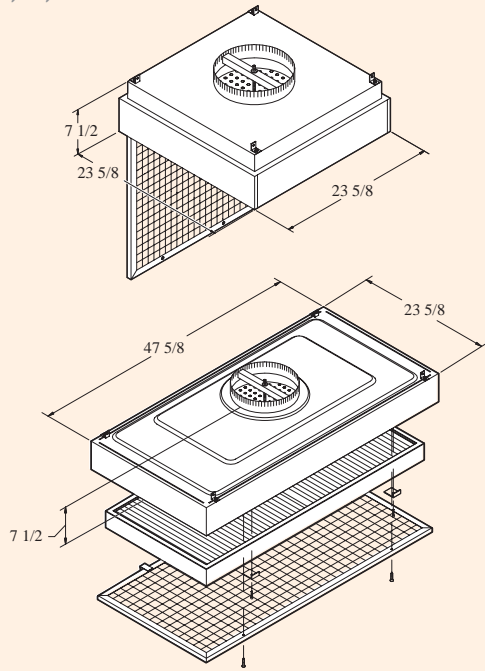

**GS Style Filter Data:** The gel seal style HEPA Filter is designed for 90 FPM average face velocity @ Initial 0.47 w.g and has a rated efficiency of 99.99% @ 0.3 micron or larger.

An anodized aluminum frame holds the 53mm media which is protected by a diamond pattern white epoxy coated steel grille. Final filters are replaceable from roomside.

**Filter Dimensions:** 20-5/8" x 20-5/8" x 3" for 2x2 units and 20-5/8" x 44-5/8" x 3" for 2x4 units.

**Access Port:** This port is located in the center of the filter element face and is used for introducing an up- stream challenge or measuring static pressure.

**Options:** ULPA Filter, thermal insulation, and a range of grille options.

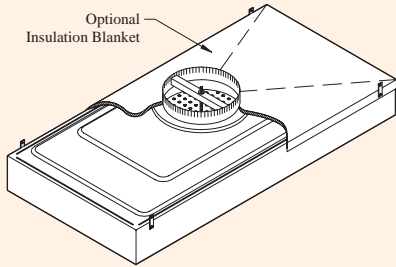

**Optional Thermal Insulation**

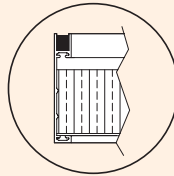

**Gel Seal Channel-Section View**

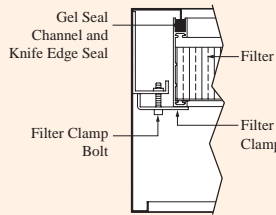

**Filter Clamp Detail**

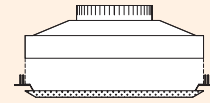

**Radial Diffuser Grille**

## Ordering Information

Mfg. Code	Nominal Size	Filter Size (In)	Inlet Collar	Efficiency	Weight
11104	2 x 2	20.62 x 20.62 x 3	10	99.99% @ 0.3	33 lbs.
11105	2 x 2	20.62 x 20.62 x 3	12	99.99% @ 0.3	33 lbs.
11106	2 x 4	20.62 x 44.62 x 3	10	99.99% @ 0.3	57 lbs.
11107	2 x 4	20.62 x 44.62 x 3	12	99.99% @ 0.3	57 lbs.

## Options

19004 2 x 2 Insulation Blanket, 1.5" Foil	302204 2 x 2 ULPA Gel Seal Filter
19005 2 x 4 Insulation Blanket, 1.5" Foil	302203 2 x 4 ULPA Gel Seal Filter

Note: See a Following Page for Grille Options

## Replacement Filters

Model	HEPA	Efficiency	ULPA	Efficiency
2 x 2 Units	302201	99.99% @ 0.3	302204	99.9995% @ 0.12
2 x 4 Units	302200	99.99% @ 0.3	302203	99.9995% @ 0.12