

Data & Specifications for SAM[®] Haz Loc

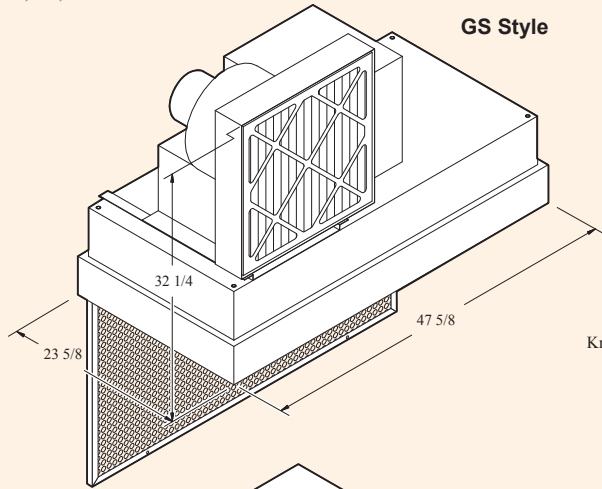

GS Style

GS Style Filter Data: Size: 20-5/8" x 44-5/8" x 3" with anodized aluminum frame, upstream gel channel and diamond pattern white epoxy face screen. The HEPA is designed for 90 FPM average face velocity @ initial 0.47 w.g. and has a rated efficiency of 99.99% @ 0.3 micron or larger.

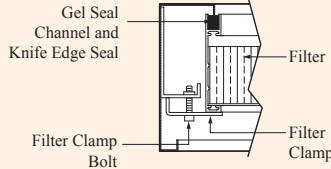

Filter Clamp Detail

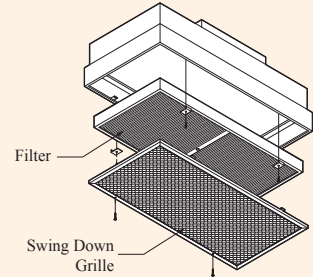

Exploded View

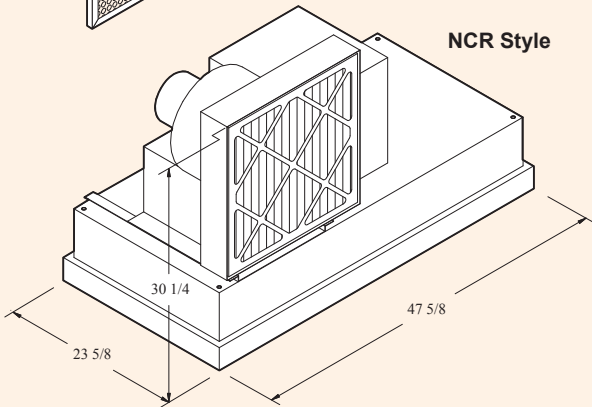

NCR Style

NCR Style Filter Data: Size: 23-5/8" x 47-5/8" x 3" with exposed anodized aluminum frame and diamond pattern white epoxy face screen. The HEPA Filter is designed for 90 FPM average face velocity @ initial 0.47 w.g. and has a rated efficiency of 99.99% @ 0.3 micron or larger.

Motor Data: SAM Haz Loc Units are equipped with an AMCA - B rated blower and Class 1 Group D, Class 2 Groups F & G motor.

CAUTION: It is always the responsibility of the customer to determine "Fitness-of-Use" of this product for the application. Clean Rooms International Inc. can not and will not make any recommendations for use of this product and will not be held liable or responsible for conditions and installations beyond our control. If you are unsure of your Hazardous Location requirement, it is advised that you contact your local Fire Marshall, OSHA, local Building Inspector or an Indoor Environmental test agency to help determine your needs.

Ordering Information

Mfg. Code	Model or Description	Style	Size	Motor	Voltage	Hz
12950*	SAM 24 Haz Loc	NCR	2 x 4	Class 1 Group D, Class 2 Group F & G	115	60
12951	SAM 24 Haz Loc	NCR	2 x 4	Class 1 Group D, Class 2 Group F & G	208-230	60
12952*	SAM 24 Haz Loc	NCR	2 x 4	Class 1 Group D, Class 2 Group F & G	277	60
12953	SAM 24 Haz Loc	NCR	2 x 4	Class 1 Group D, Class 2 Group F & G	208/460	60
12954	SAM 24 Haz Loc GS	GS	2 x 4	Class 1 Group D, Class 2 Group F & G	115	60
12955	SAM 24 Haz Loc GS	GS	2 x 4	Class 1 Group D, Class 2 Group F & G	208/230	60
12956	SAM 24 Haz Loc GS	GS	2 x 4	Class 1 Group D, Class 2 Group F & G	277	60
12957	SAM 24 Haz Loc GS	GS	2 x 4	Class 1 Group D, Class 2 Group F & G	208-460	60

Replacement Filters

302090	NCR Style HEPA Filter, 99.99% eff. @ 0.3 micron
302100	NCR Style ULPA Filter, 99.9995% eff. @ 0.12 micron
302200	GS Style HEPA Filter, 99.99% eff. @ 0.3 micron
302203	GS Style ULPA Filter, 99.9995% eff. @ 0.12 micron
302190	Prefilter 20" x 20" x 1", 30% ASHRAE efficient, pleated type
Note: Consult with the factory for horizontal flow applications	