

Features 4-Lamp Flow-Thru Light Troffer Gel Seal Style HEPA or ULPA Filter Replaceable From Roomside

GS LI Terminal Diffusers are ideal for pharmaceutical companies, manufacturers of medical devices and companies in highly regulated industries. The GS LI series feature a gel channel on the upstream side of the final filter which provides a leak-free seal between the filter and the housing.

GS LI Terminal Diffusers feature an integral “flow-thru” 4-lamp light fixture and a HEPA or ULPA filter replaceable from roomside.

The white powdercoated housing, fabricated from 20 gauge steel, is positively sealed to a hood fabricated from galvanized steel.

A 10" or 12" diameter inlet collar at the center of the filter hood allows for simple field connection to the main air supply using flexible duct.

The damper assembly is adjustable from within the room and is supported by a damper support channel permanently attached to the filter hood duct collar. A perforated damper disc is mounted on threaded rod and a guide provides screwdriver adjustments of the damper assembly from roomside.

An acrylic eggcrate grille in an anodized aluminum frame is hinged to open, permitting removal of the HEPA or ULPA filter without removing the complete unit from the ceiling.

Final filters are protected with a white epoxy diamond grille and are tested according to accepted procedures as described by the Institute of Environmental Sciences (IEST) and/or ISO standards. The standard HEPA filter is 99.99% eff. and an ULPA grade 99.9995% eff. filter is available as an option.

The integral light fixture and T8 multi-voltage electronic ballast is located inside the filter housing below the final HEPA filter. This permits fluorescent light bulbs or ballast to be replaced easily. A junction box is located on top of the unit for easy connection to the building power system.

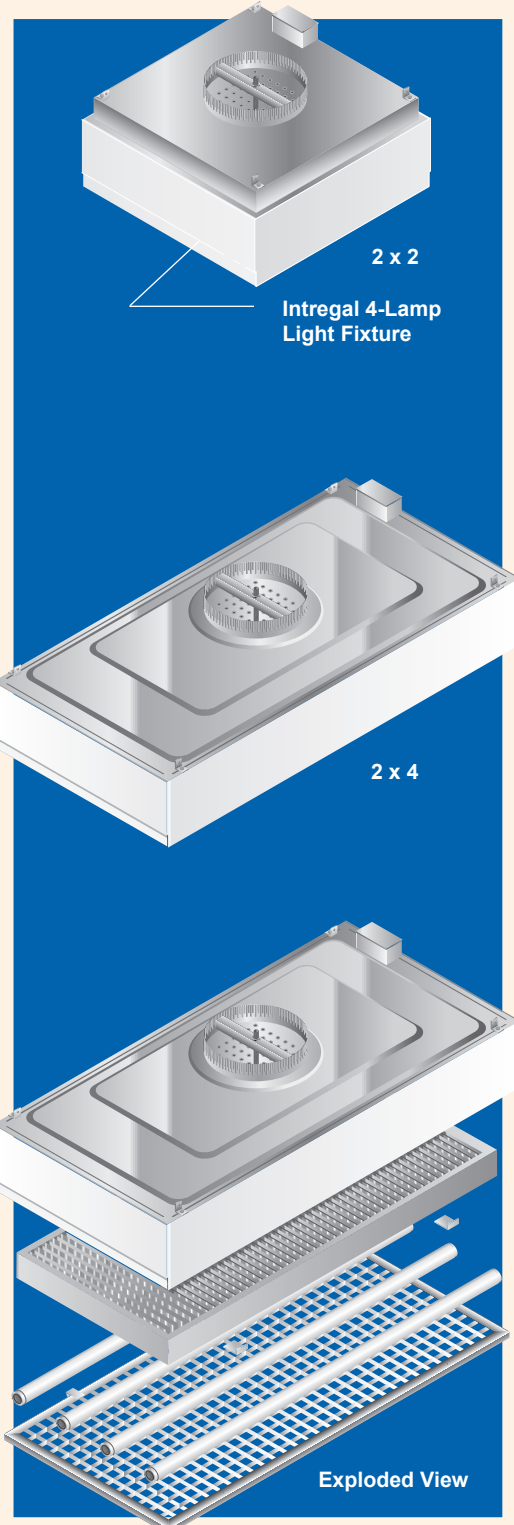

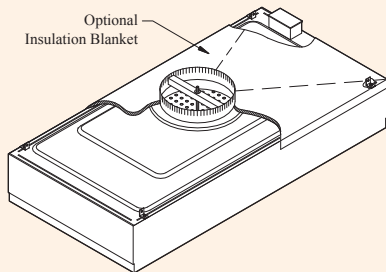
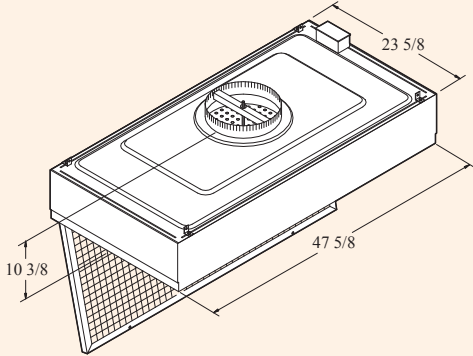
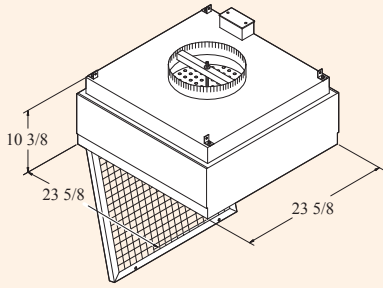

Optional Thermal Insulation

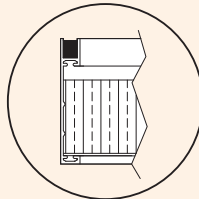

Gel Seal Channel-Section View

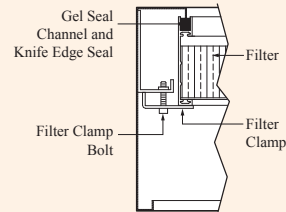

Filter Clamp Detail

GS Style Filter Data: The gel seal style HEPA Filter is designed for 90 FPM average face velocity @ Initial 0.47 w.g and has a rated efficiency of 99.99% @ 0.3 micron or larger.

An anodized aluminum frame holds the 53mm media which is protected by a diamond pattern white epoxy coated steel grille. Final filters are replaceable from roomside.

Filter Dimensions: 20-5/8" x 20-5/8" x 3" for 2x2 units and 20-5/8" x 44-5/8" x 3" for 2x4 units.

Lights: Integral 4-lamp Light Fixture with T8 Electronic Multi-Voltage Ballast. Fluorescent light tubes are not included.

Options: ULPA Filter and thermal insulation.

Ordering Information

Mfg. Code	Nominal Size	Filter Size (In)	Inlet Collar	Efficiency	Multi-Voltage	Weight
11108	2 x 2	20.62 x 20.62 x 3	10	99.99% @ 0.3	120V to 277V	35 lbs.
11109	2 x 2	20.62 x 20.62 x 3	12	99.99% @ 0.3	120V to 277V	35 lbs.
11110	2 x 4	20.62 x 44.62 x 3	10	99.99% @ 0.3	120V to 277V	70 lbs.
11111	2 x 4	20.62 x 44.62 x 3	12	99.99% @ 0.3	120V to 277V	70 lbs.

Options

19004 2 x 2 Insulation Blanket, 1.5" Foil	302204 2 x 2 ULPA Gel Seal CRF Filter
19005 2 x 4 Insulation Blanket, 1.5" Foil	302203 2 x 4 ULPA Gel Seal CRF Filter
Note: See a Following Page for Grille Options	

Replacement Filters

Model	HEPA	Efficiency	ULPA	Efficiency
2 x 2 Units	302201	99.99% @ 0.3	302204	99.9995% @ 0.12
2 x 4 Units	302200	99.99% @ 0.3	302203	99.9995% @ 0.12