

Work Surfaces

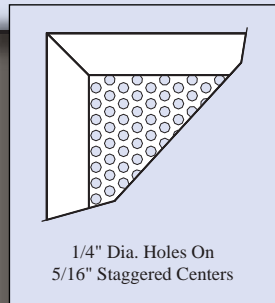

Perforated SS Work Surfaces	Part No.	Description
	19101	SS Work Surface 24" D for 2 Ft Clean Bench
	19102	SS Work Surface 24" D for 4 Ft Clean Bench
	19103	SS Work Surface 24" D for 6 Ft Clean Bench
	19104	SS Work Surface 24" D for 8 Ft Clean Bench
	19105	SS Work Surface 32" D for 2 Ft Clean Bench
	19106	SS Work Surface 32" D for 4 Ft Clean Bench
	19107	SS Work Surface 32" D for 6 Ft Clean Bench
19108	SS Work Surface 32" D for 8 Ft Clean Bench	

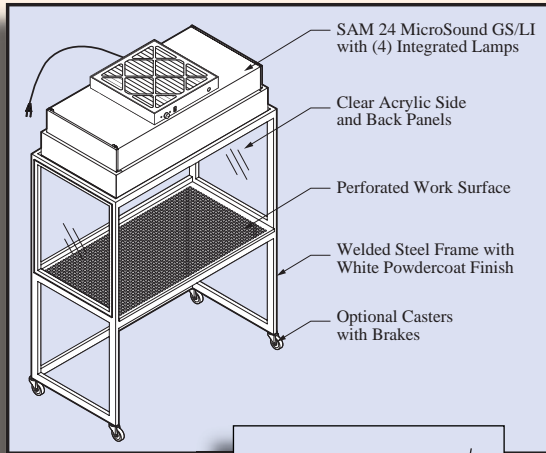
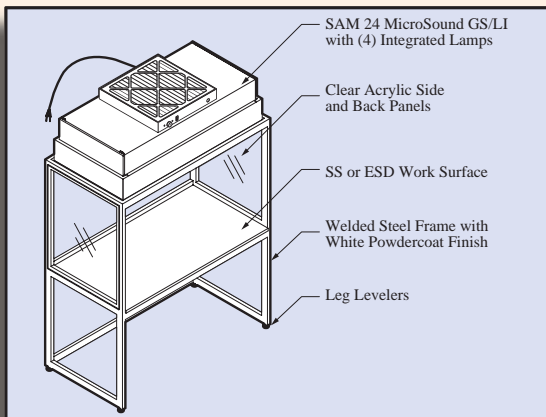

Stainless Steel Work Surfaces	Part No.	Description
	19109	SS Work Surface 24" D for 2 Ft Clean Bench
	19110	SS Work Surface 24" D for 4 Ft Clean Bench
	19111	SS Work Surface 24" D for 6 Ft Clean Bench
	19112	SS Work Surface 24" D for 8 Ft Clean Bench
	19113	SS Work Surface 32" D for 2 Ft Clean Bench
	19114	SS Work Surface 32" D for 4 Ft Clean Bench
	19115	SS Work Surface 32" D for 6 Ft Clean Bench
19116	SS Work Surface 32" D for 8 Ft Clean Bench	

ESD Work Surfaces	Part No.	Description
	19117	ESD Work Surface 24" D for 2 Ft Clean Bench
	19118	ESD Work Surface 24" D for 4 Ft Clean Bench
	19119	ESD Work Surface 24" D for 6 Ft Clean Bench
	19120	ESD Work Surface 24" D for 8 Ft Clean Bench
	19121	ESD Work Surface 32" D for 2 Ft Clean Bench
	19122	ESD Work Surface 32" D for 4 Ft Clean Bench
	19123	ESD Work Surface 32" D for 6 Ft Clean Bench
19124	ESD Work Surface 32" D for 8 Ft Clean Bench	

Casters

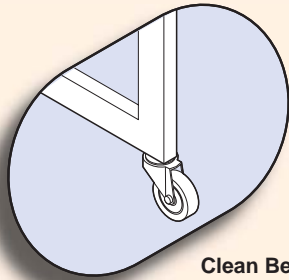

Clean Bench

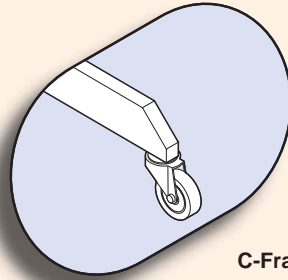

C-Frame

Caster Option	
Part No.	Description
805083	Caster, 3" w/Brakes, (4) req'd.

Static Control Package

Static Pulse Box Controller is pre-wired and installed in 4ft, GS unit

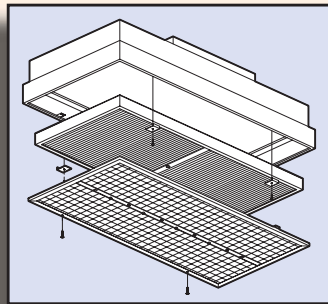

Part No.	Description
19754	2' models, 115V, 60Hz
19755	2' models, 208-230V, 50/60Hz
19750	4' models, 115V, 60Hz
19751	4' models, 208-230V, 50/60Hz
19752	6' models, 115V, 60Hz
19753	6' models, 208-230V, 50/60Hz
19756	8' models, 115V, 60Hz
19757	8' models, 208-230V, 50/60Hz

Duct Collar Adapters

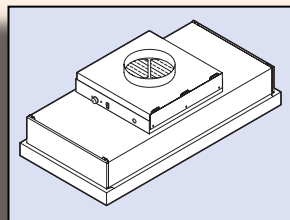
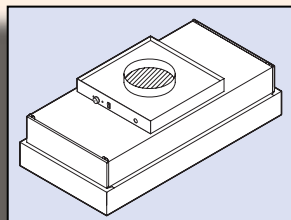

Part No.	Description
19950	10" Duct Collar Adapter
19951	12" Duct Collar Adapter
19952	Side Load Prefilter Frame w/10" Duct Collar Adapter
19953	Side Load Prefilter Frame w/12" Duct Collar Adapter
NOTE: (2) required for SAM 26 Models	

Additional Options	
208-230V, 50/60 hz motor	250V, 50 hz lighting for export models
277V, 60 hz motor	ULPA Filter 99.9995% eff @ 0.12 micron or larger

Consult the factory for more information

Front Face Shields

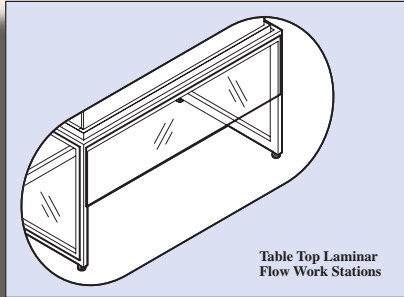
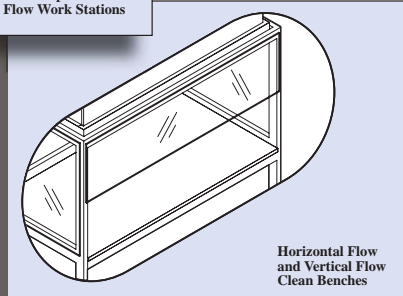
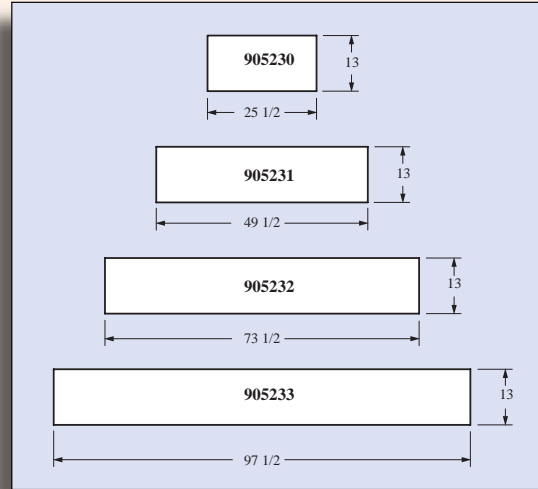

Table Top Laminar Flow Work Stations



Horizontal Flow and Vertical Flow Clean Benches



Face Shield Dimensions

Part No.	Description	Part No.	Description
905230	Acrylic Face Shield for 2 Ft Bench	905232	Acrylic Face Shield for 6 Ft Bench
905231	Acrylic Face Shield for 4 Ft Bench	905233	Acrylic Face Shield for 8 Ft Bench

Top Shroud

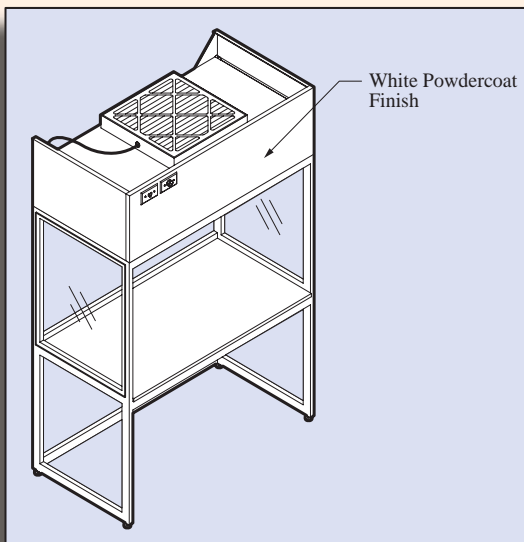

Top Shroud

Top Shrouds are available for enclosing the SAM unit. Easy access to the switches enables the operator to operate the lights independently from the fan motor.

Top Shroud	
Part No.	Description
Vertical Flow	
19140	Top Shroud Unit 24" D for 2 Ft Clean Bench
19141	Top Shroud Unit 24" D for 4 Ft Clean Bench
19142	Top Shroud Unit 24" D for 6 Ft Clean Bench
19143	Top Shroud Unit 24" D for 8 Ft Clean Bench
19144	Top Shroud Unit 32" D for 2 Ft Clean Bench
19145	Top Shroud Unit 32" D for 4 Ft Clean Bench
19146	Top Shroud Unit 32" D for 6 Ft Clean Bench
19147	Top Shroud Unit 32" D for 8 Ft Clean Bench
Horizontal Flow	
19148	Top Shroud Unit 24" D for 2 Ft Clean Bench
19149	Top Shroud Unit 24" D for 4 Ft Clean Bench
19150	Top Shroud Unit 24" D for 6 Ft Clean Bench
19151	Top Shroud Unit 24" D for 8 Ft Clean Bench
19152	Top Shroud Unit 32" D for 2 Ft Clean Bench
19153	Top Shroud Unit 32" D for 4 Ft Clean Bench
19154	Top Shroud Unit 32" D for 6 Ft Clean Bench
19155	Top Shroud Unit 32" D for 8 Ft Clean Bench