

Magnehelic Gages:

Monitoring the static pressure within the room can be accomplished by adding a Magnehelic Gage. (Fig. 6)

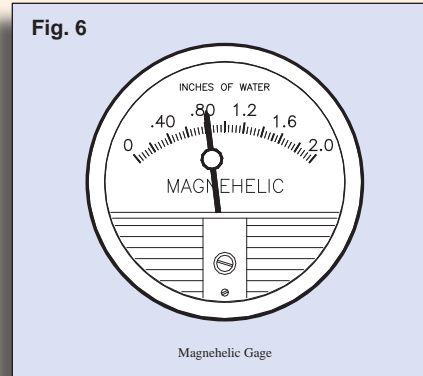

Perimeter Fascia:

An attractive white painted sheet metal perimeter fascia (Fig. 7) prevents viewing the ceiling components from outside the room.

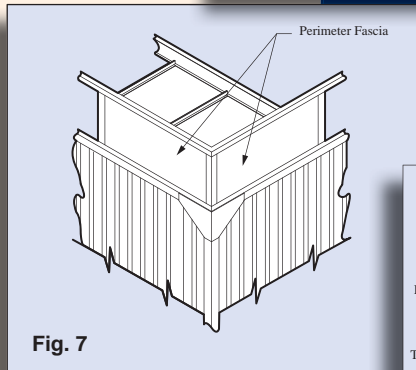

Telescoping Legs:

Legs are adjusted by removing the pin, sliding the leg to another desired height and replacing the pin. (Fig. 8) This feature is useful when the cleanroom must be moved through a doorway to another area.

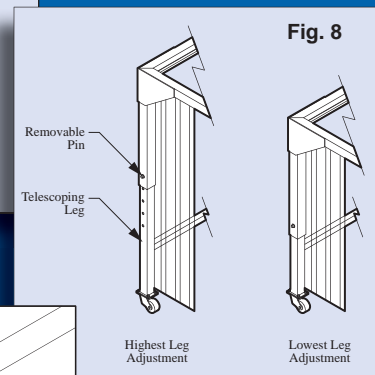

Optional strip doors with alternating frosted strips reduces friction between the strips and extends the life of the door. (Fig. 9)

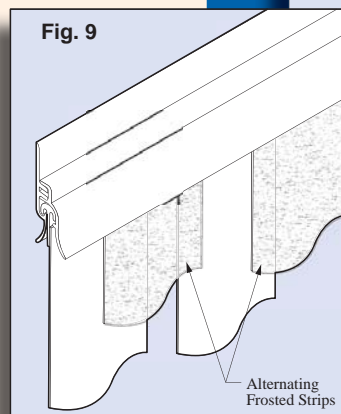

More Options:

Consult with your area representative or the CRI factory for your unique requirements.

Softwall Cleanrooms

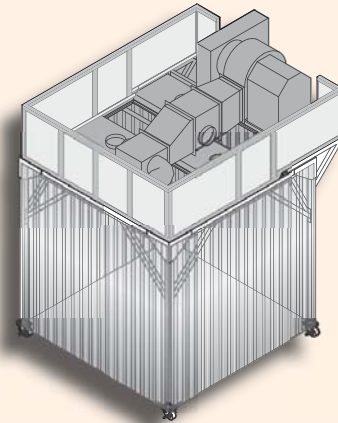
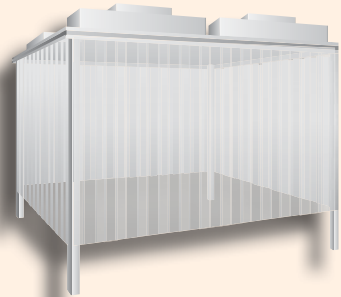

**Clean Rooms
International**
Designing Flexible Solutions

The manufacturer warrants this equipment to be free from defects in material and workmanship for a period of one (1) year from date of purchase.

No other warranty is herein expressed and none shall be implied.

If failure appears within one (1) year from date of purchase, the buyer must notify the Company immediately. Documentary proof of length of service (which shall include date of purchase) must be furnished to Company if the date of manufacture was more than one (1) year prior to the date of alleged failure. Defective product may be delivered freight prepaid to the nearest Company authorized location. Company shall, at its option, correct the defect, or supply a replacement.

The liability of Company shall not in any case exceed either the cost of correcting defects in the product or supplying a replacement for that, whichever shall be less, and upon the expiration of one (1) year from date of purchase of product by customer all such liability shall terminate.

Company is not responsible for damage to product due to abuse, improper installation, use other than for which originally sold, or through operation above rated load, either intentionally or otherwise of any product or party. Under no circumstances will manufacturer be responsible for any freight (in or out), installation, or removal costs.

The foregoing warranty is in lieu of all other warranties, express or implied, with respect to the product, including any implied or statutory warranty of merchantability or fitness for purpose. Company shall not be liable by virtue of this warranty, or otherwise, for any consequential, incidental or special loss or damage resulting from the use or loss of use of the product.