

## Product Data & Specifications

### SAM44 Introduction

Providing clean environments begins with precise production. We use industry leading standards throughout our design and manufacturing process to create products and solutions that will have trustworthy performance.

Serving inventive customers requires versatile solutions. The SAM44 is our solution for large scale cleanrooms that also have an eye on energy efficiency.

### Standard Features

All SAM44 Fan Filter Units include:

- UL listed
- HEPA filter 99.99% eff. @ 0.3 micron
- Modbus interface card for speed control through BMS
- 200-277V 50/60 Hz EC motor
- CAT5 connection
- On/Off switch
- Handles
- Protective inlet screen
- Aluminum construction, mill finish

Final filter is protected with a white epoxy diamond pattern grille and are tested according to accepted procedures as described by the Institute of Environmental Sciences (IEST) and/or ISO standards.

### Optional Features

- ULPA filter 99.9995% eff. @ MPPS
- BACnet MSTP or BACnet IP control via BMS
- Local control via potentiometer



## Product Data & Specifications

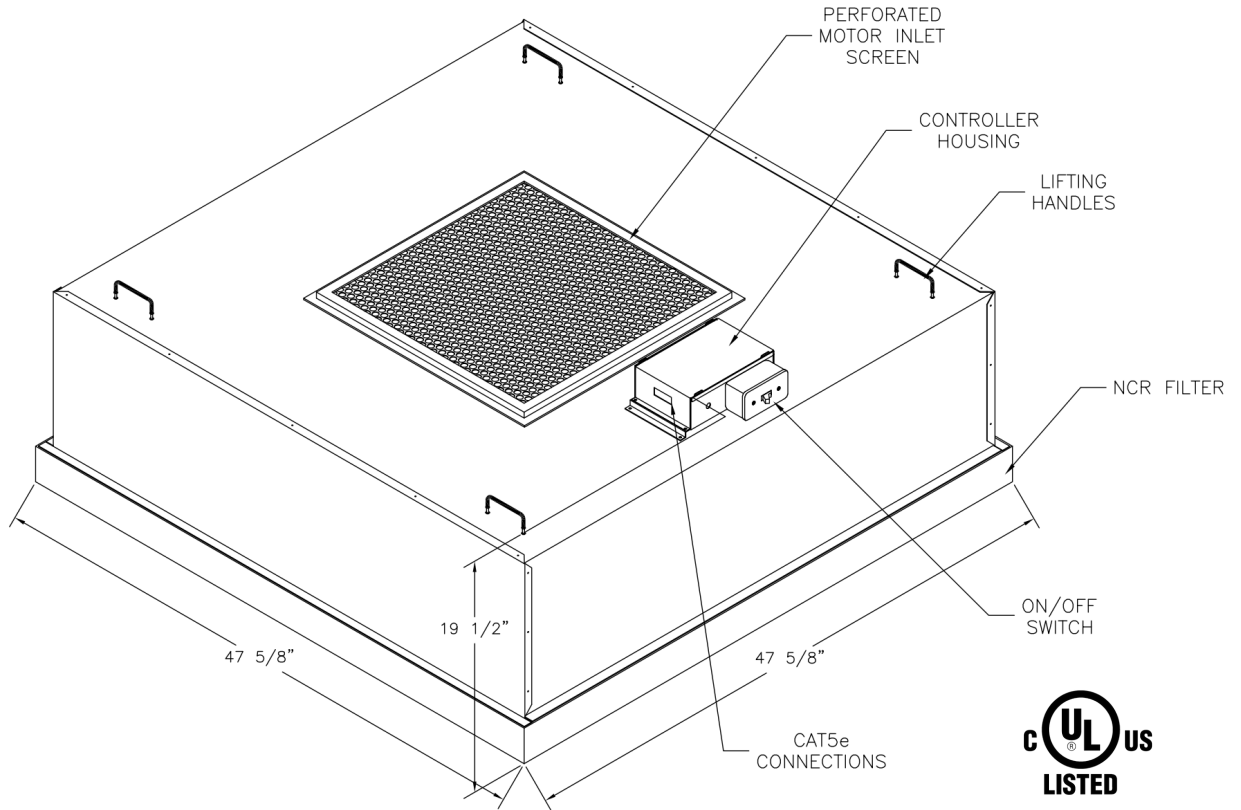

Performance Data								
Mfg. Code	Model	Size	Max CFM	Watts @ Max CFM	Amps @ Max CFM	CFM @ 90 FPM	Watts @ 90FPM	Amps @ 90 FPM
12400	SAM 44 NCR	4 x 4	2018	260	0.95	1513	131	0.504

SAM 44 meets the requirements of IEST-RP-CC036.1

Replacement Filters	
Mfg. Code	Description
302230	4 x 4 NCR HEPA Filter 99.99% eff. @ 0.3 micron
302300	4 x 4 NCR ULPA Filter 99.9995% eff. @ MPPS

Controls	
Mfg. Code	Description
509235	Gateway for BACnet MSTP or BACnet IP