

Cleanroom T-Bar and Lights

Our T-Grid Ceiling Systems Enhance Cleanroom Security

Clean Rooms International advances cleanroom standards with its ceiling system components. Our state-of-the-art systems help tight-tolerance temperature and humidity-controlled environments conform with the latest government and industry standards. After ceiling blanks, light fixtures, and filters are installed in the grid, a secure, airtight barrier is formed against dust and moisture for sensitive cleanroom needs.

For more information about our Ceiling Systems and other cleanroom products and services, consult with a Clean Rooms International factory representative.

T-Grid Systems

Our 2" Heavy Duty, Walkable, and Slotted suspension hardware is interchangeable, providing easy adjustment for installing the ceiling dead level.

Cleanroom Light Fixtures

Sealed fixtures made especially for cleanrooms, maintenance free. Features include a 120-277 multi-voltage long life LED system.

NOTE: Fluorescent lighting available in certain configurations.

Teardrop Lights

A narrow airfoil design to minimize turbulence in cleanrooms requiring a unidirectional air flow, and can be easily mounted on 2" T-Bar.

Flow-Through Light Troffers

Accept a SAM® Filter Unit on the top and allow HEPA or ULPA filtered air to flow through the fixture and into the cleanroom.

Cleanguard Cleanroom Ceiling Panels

Feature factory-sealed edges and a white vinyl face.

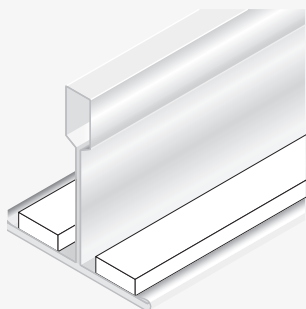

1.5" Gasket Seal

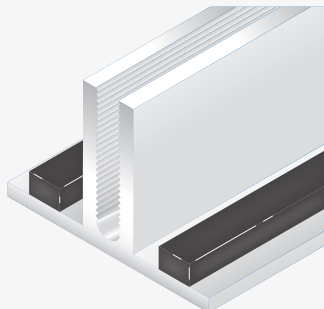

2" Gasket Seal

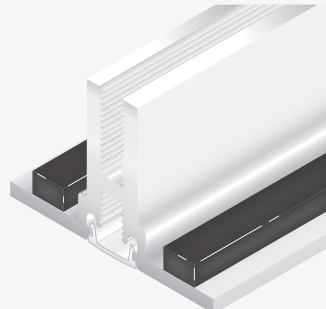

2" Gasket Seal
(Slotted)

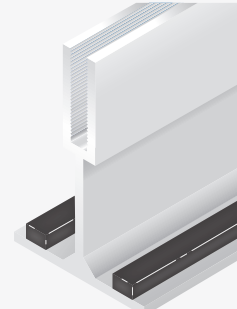

2" Walkable
T-Grid

CRI's Unique Suspension Hardware and Intersection Connectors Provide Superior Load-Bearing Capacity

