

sales@cleanroomsint.com
616.452.8700

QS Series Softwall Cleanrooms

QS Series Flexible Solutions Standard Specifications

Frame: Prefabricated white painted steel frame.

Leg: Bottom base plate with four (4) mounting holes.

Ceiling System: Painted support structure and white painted steel T-Grid.

Curtain Panels: All sides are enclosed with clear vinyl 40 mil curtain panels. Length is pre-engineered for proper air flow relief, appropriate for size and classification

Entry Door: Via a 4' strip door consisting of 8" 80 mil alternating frosted and clear vinyl strips overlapped 2". Individual strips are installed on an aluminum mounting track. The strip door is attached to the cleanroom frame on-site during assembly.

Interior Height: Eight (8) Feet.

Lighting: 2' x 4' LED cleanroom light fixtures with sealed housings and polystyrene lens.

Ceiling Panels: Cleanguard ceiling panels with sealed edges and white vinyl laminate on one side for spaces not occupied by SAM Fan Filter Units or light fixtures.

HEPA Filters: SAM 2' x 4' Fan Filter Units, 115V manufactured by Clean Rooms International.

Electrical: Electrical connections to the building power source are to be completed on site by a qualified electrician at buyer's cost.

Assembly: Detailed assembly instructions included with shipment.

Classifications Offered

ISO Class 6, 7, & 8

Federal Standard 209 Class 1,000, 10,000, & 100,000

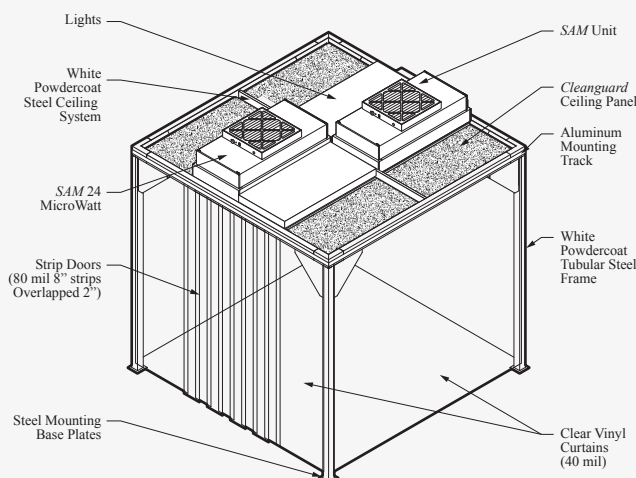

Curtain Length is Pre-engineered for Proper Air Flow Relief
Typical Softwall Cleanroom

Ship Within 2-3 Weeks A.R.O., Easy To Install in One Day,
Unmatched Structural Integrity, & Easy To Upgrade

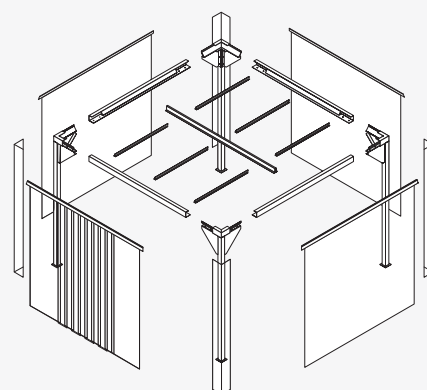

Softwall Cleanroom
(Exploded View)

(ISO Class 6) Class 1,000 (Ordering Information)

Model No.	Sizes W x L	Inside Ceiling HR	Volts	No. SAM's	No. Lights	Ceiling Panels	4' Door	Legs
10006	8' x 8'	8'	115V	2	2	4	1	4*
10007	8' x 10'	8'	115V	3	2	5	1	4*
10008	8' x 12'	8'	115V	4	3	5	1	4*
10010	8' x 16'	8'	115V	5	4	7	1	6
10011	10' x 12'	8'	115V	5	3	7	1	4*
10012	10' x 16'	8'	115V	6	4	10	1	6
10013	12' x 12'	8'	115V	5	4	9	1	4*
10014	12' x 16'	8'	115V	7	5	12	1	6
10015	12' x 20'	8'	115V	9	6	15	1	6
10016	12' x 24'	8'	115V	11	7	18	1	6

Note: No dimension modifications are available for the QS Series. | * Available with castors. Refer to a following page. | See a following page for electrical options.

(ISO Class 7) Class 10,000 (Ordering Information)

Model No.	Sizes W x L	Inside Ceiling HR	Volts	No. SAM's	No. Lights	Ceiling Panels	4' Door	Legs
10022	8' x 8'	8'	115V	1	2	5	1	4*
10023	8' x 10'	8'	115V	2	2	6	1	4*
10024	8' x 12'	8'	115V	2	3	7	1	4*
10026	8' x 16'	8'	115V	2	4	10	1	6
10027	10' x 12'	8'	115V	2	3	10	1	4*
10028	10' x 16'	8'	115V	3	4	13	1	6
10029	12' x 12'	8'	115V	3	4	11	1	4*
10030	12' x 16'	8'	115V	3	5	16	1	6
10031	12' x 20'	8'	115V	4	6	20	1	4*
10032	12' x 24'	8'	115V	5	7	24	1	6

Note: No dimension modifications are available for the QS Series. | * Available with castors. Refer to a following page. | See a following page for electrical options.

(ISO Class 8) Class 100,000 (Ordering Information)

Model No.	Sizes W x L	Inside Ceiling HR	Volts	No. SAM's	No. Lights	Ceiling Panels	4' Door	Legs
10038	8' x 8'	8'	115V	1	2	5	1	4*
10039	8' x 10'	8'	115V	1	2	7	1	4*
10040	8' x 12'	8'	115V	1	3	8	1	4*
10042	8' x 16'	8'	115V	1	4	11	1	6
10043	10' x 12'	8'	115V	1	3	11	1	4*
10044	10' x 16'	8'	115V	1	4	15	1	6
10045	12' x 12'	8'	115V	1	4	13	1	4*
10046	12' x 16'	8'	115V	2	5	17	1	6
10047	12' x 20'	8'	115V	2	6	22	1	6
10048	12' x 24'	8'	115V	2	7	27	1	6

Note: No dimension modifications are available for the QS Series. | * Available with castors. Refer to a following page. | See a following page for electrical options.