

# 4' Teardrop Light Fixture

## Mounting Data

Illustration A shows the power connection through the top of the fixture and the T-Bar. A hole must be drilled in the T-Bar for allowing the wires to pass through. Knockouts are located on each end of the top surface for allowing power connections. The fixture is secured to the T-Bar through the holes located on the top of the fixture as shown in Illustration B.

Illustration B is same as A but with an exploded view of the fixture.

Illustration C is an exploded view showing the power connection at the end of the fixture. Knockouts are provided on each end cap for allowing power connections. The fixture is secured to the T-Bar through holes located on the top of the fixture as shown. This method is suitable for continuous row mounting.

## Ordering Information

| Part No. | Nominal Size | Voltage   | Cycle    | Ballast       | Amps | Watts  | Weight            |
|----------|--------------|-----------|----------|---------------|------|--------|-------------------|
| 148054   | 4'           | 120V-277V | 50/60 Hz | T8 Electronic | *1   | 32/128 | 12 lbs. (5.5 kg.) |

\*1. 120V = .26 amps, 277V = .12 amps

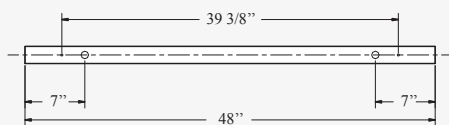

Mounting Diagram

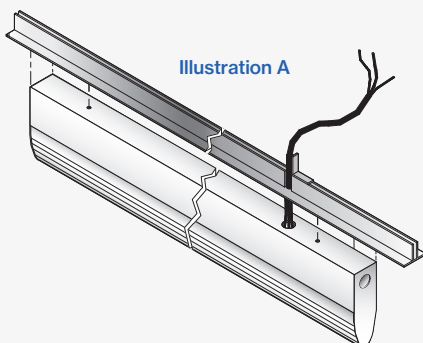

Illustration A

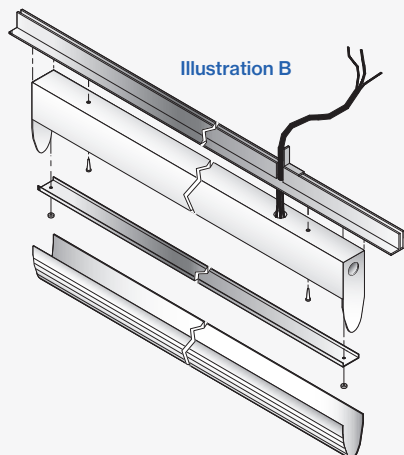

Illustration B

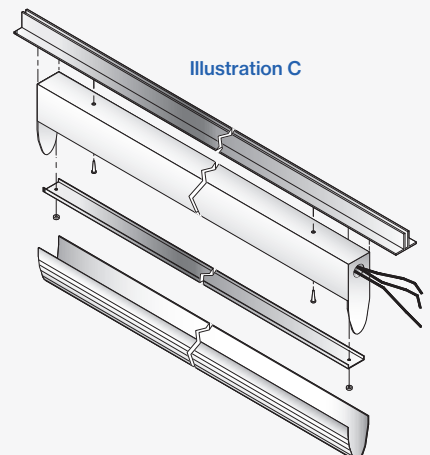
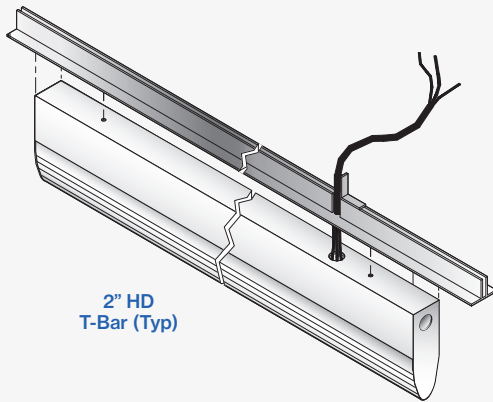

Illustration C



2" HD  
T-Bar (Typ)

Manufactured in compliance with  
USDA, FDA, and NSF guidelines.

UL listed.

Suitable for use in VERTICAL  
LAMI NAR AIR FLOW  
cleanrooms.

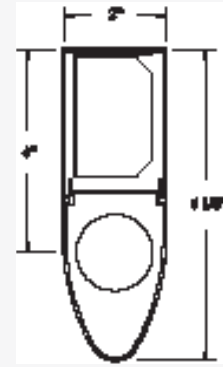

End View  
(Shown with end cap removed)

### Air Foil Design

Clean Rooms International's Teardrop Light Fixture features a narrow, airfoil design which minimizes turbulence in cleanrooms requiring a unidirectional air flow. The fixture is suitable for use in Federal Standard 209 Class 100 to 100,000 and ISO Class 5 to 9 cleanroom environments.

Applications include but not limited to cleanrooms, technical and biomedical labs, food processing centers and pharmaceutical labs.

### Smooth Environmental Side

A one-piece, clear extruded, prismatic acrylic lens with internal horizontal prism pattern maintains a smooth environmental side. White, closed cell gasketing seals the lens to end caps and prevents entrapment of biohazardous contaminants which could grow inside the fixture.

The enclosed 2" wide gasketed housing can be mounted on any 2" T-Bar. Recessed, 7/8" diameter knockouts-one on each end cap and one at each end of the mounting surface-allow connection of vapor tight conduit fitting for either continuous row mounting or top access.

### Sealed End Caps

Housings are die-formed, 22 ga. CRS with 16 ga., spot welded and sealed end caps. Standard white high reflectance polyester powder coat finish. Gloss: 85%; Reflectance: 93%; Hardness: 2H; Salt Spray: 500 Hours.

A standard 4' fixture is equipped with a 120-277 Multi-voltage T8 electronic ballast and receptacles to accept one F32 T8 fluorescent lamp tube (lamp tube not included).

### Regulatory Compliance

These luminaries are UL listed and CSA certified for wet locations and are manufactured in accordance with USDA, FDA, and NSF guidelines. All fixtures have been tested and reported in compliance with Federal Standard 209.