

SAM MS 3S GS Style

1/5 HP, 3-Speed Fan Powered, Filter Module, GS, Low Sound, and Economical

SAM MS 3-S GS Fan Filter Units provide quiet performance and economy while delivering 90 FPM airflow velocities, perfect for most cleanroom applications. Base design includes a 99.99% efficient HEPA filter, a prefilter and a 3-speed switch with an off position which disables the unit while servicing.

Housings are fabricated from steel with a white powdercoat finish and include seismic clip suspension points.

The 1/5 HP motor blower is a forward curved direct drive motor/blower assembly with isolation mounts. Units are available in 115 Volt (60 Hz) and 277 Volt (60 Hz).

Final filters are protected with a white epoxy diamond pattern grille and are tested according to

accepted procedures as described by the Institute of Environmental Sciences (IEST) and/or ISO standards. The standard HEPA filter is 99.99% efficient and an ULPA grade 99.9995% efficient filter is available as an option.

A polystyrene eggcrate grille in an anodized aluminum frame hinged to open is included, permitting removal of the filter without removing the unit from the ceiling. Optional perforated stainless steel or aluminum grilles are available.

Other popular options include an 8' power cord (115 Volt only). Refer to the back of this section for more options and accessories.

GS Style Filter Data

The HEPA Filter is designed for 90 FPM average face velocity @ initial 0.47 w.g. and has a rated efficiency of 99.99% @ 0.3 micron or larger.

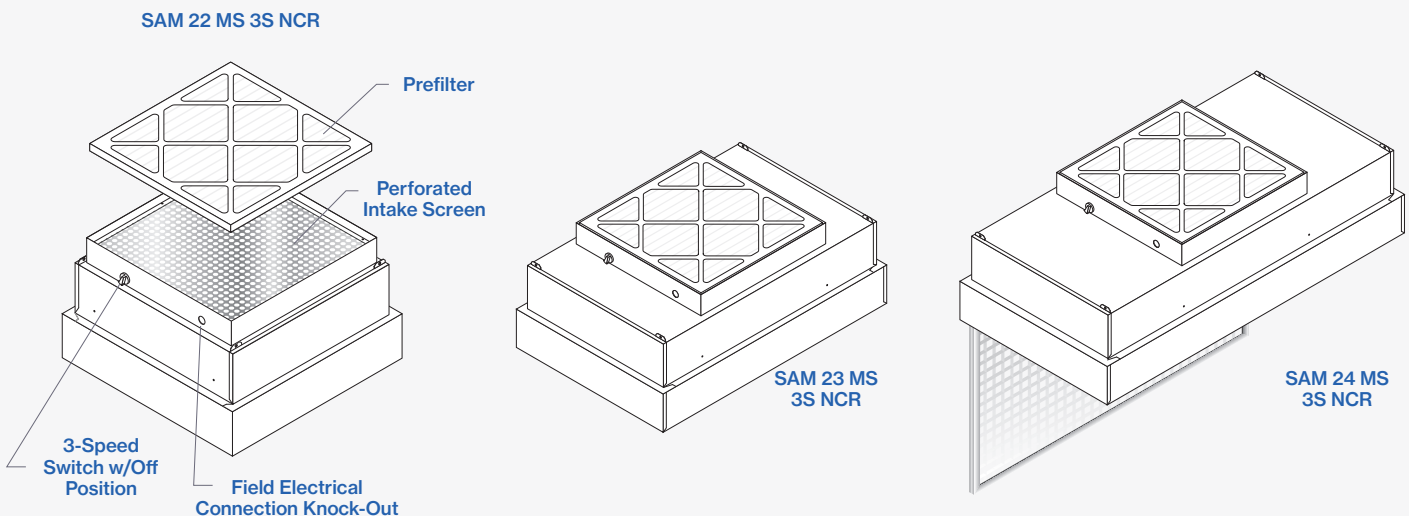

An anodized aluminum frame holds the 53mm media which is protected by a diamond pattern white epoxy coated steel grille. Final filters are replaceable from roomside.

Access Port

This port is located in the center of the filter element face and is used for introducing an upstream challenge or measuring static pressure.

Air Flow

Airflow ranges from 425 to 675 CFM for a 2 x 4 unit and 220 to 300 CFM for a 2 x 2 unit. At 90 FPM, CFM is nominal 510 on a 2 x 4 and 250 on a 2 x 2 unit respectively.

Replacement Filters	
Mfg. Code	Description
302201	2 x 2 GS Style HEPA Filter, 99.99% efficient @ 0.3 micron
302204	2 x 2 GS Style ULPA Filter, 99.9995% efficient @ 0.12 micron
302214	2 x 3 GS Style HEPA Filter, 99.99% efficient @ 0.3 micron
302215	2 x 3 GS Style ULPA Filter, 99.9995% efficient @ 0.12 micron
302200	2 x 4 GS Style HEPA Filter, 99.99% efficient @ 0.3 micron
302203	2 x 4 GS Style ULPA Filter, 99.9995% efficient @ 0.12 micron
302190	Prefilter 20" x 20" x 1", 30% ASHRAE efficient, pleated type

Standard Ceiling Size

All 2' x 4' models are designed to fit a nominal 2' x 4' ceiling grid with a 22.5" x 46.5" standard opening.

Sound Level

At average face velocity of 90 FPM measured 30" from face of filter, sound level is approximately 50-52 dba with less than 45 dba ambient sound level. Field conditions, voltage and method of testing could produce different results.

Popular Options

Refer to a following page for a list of popular options.

Motor Data			
Motor	Voltage	Hz	Amps
1/5 HP	115	60	3.1
1/5 HP	277	60	1.1

(1) Line voltage can affect actual start-up amperage
 (2) Use standard NEC tables for sizing circuits

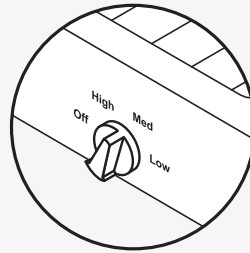
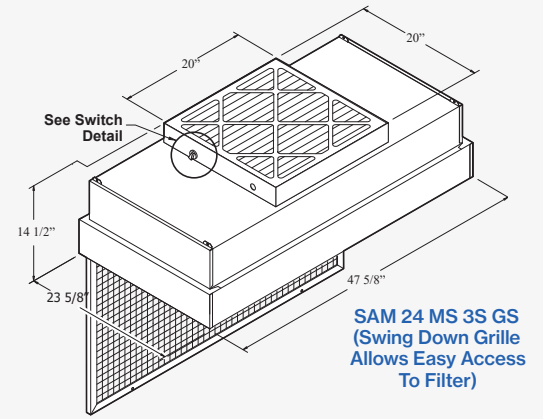
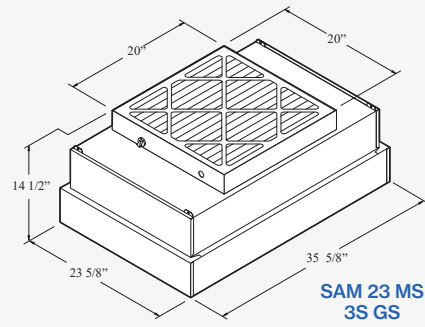
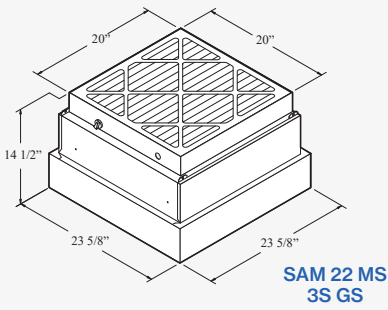

Switch Detail 115V/277V

Base Model (Ordering Information)

Mfg. Code	Model	Style	Size	Voltage	Motor	HEPA Filter	Weight
12341	SAM 22 MS 3S GS*	GS	2 x 2	115	1/5 HP	302201	72 lbs. (32.7 kg.)
12342	SAM 22 MS 3S GS*	GS	2 x 2	277	1/5 HP	302201	72 lbs. (32.7 kg.)
12345	SAM 23 MS 3S GS*	GS	2 x 3	115	1/5 HP	302214	83 lbs. (37.6 kg.)
12346	SAM 23 MS 3S GS*	GS	2 x 3	277	1/5 HP	302214	83 lbs. (37.6 kg.)
12349	SAM 24 MS 3S GS*	GS	2 x 4	115	1/5 HP	302200	91 lbs. (41.3 kg.)
12350	SAM 24 MS 3S GS*	GS	2 x 4	277	1/5 HP	302200	91 lbs. (41.3 kg.)

* UL Listed
3 Speed Switch Standard on all Models

Popular Options: (Please choose from the following part numbers when ordering options)

Speed Control:

- 3-Speed Switch
- SAMLink Remote Speed Control System

Final Filters:

- 302204 2 x 2 GS ULPA Filter 99.9995% efficient
- 302214 2 x 3 GS ULPA Filter 99.9995% efficient
- 302203 2 x 4 GS ULPA Filter 99.9995% efficient

Prefilters:

- 302197 Extended Life Prefilter 20" x 20" x 2"

Grilles 1/8" Round Perforated: (40% open area)

- 19506 2 x 2 CRF Anodized Aluminum Grille and Frame
- 19507 2 x 4 CRF Anodized Aluminum Grille and Frame
- 19508 2 x 2 CRF Round Perforated with 1/8" Holes, White Powdercoated Grille and Frame
- 19509 2 x 4 CRF Round Perforated with 1/8" Holes, White Powdercoated Grille and Frame
- 19511 2 x 4 CRF S.S. Round Perf Grille with Anodized Aluminum Frame
- 19512 2 x 2 CRF S.S. Round Perf Grille with Anodized Aluminum Frame
- 19514 2 x 4 CRF S.S. Perf Grille with S.S. Frame

Duct Collar Adapters:

- 19950 10" Duct Collar Adapter
- 19951 12" Duct Collar Adapter
- 19952 Side Load with 10" Duct Collar
- 19953 Side Load with 12" Duct Collar
- 19955 10" Top Load Duct Collar Adapter
- 19956 12" Top Load Duct Collar Adapter

Pilot Light:

- 19702 GS/CRF Style Red Pilot Light - factory mounted in grille frame (Light Indicates Power to Motor)
- 19703 GS/CRF Style Red Pilot Light with Pressure Switch - factory mounted in grille frame (Light Indicates Air Flow)

Air Conditioning Mixing Box:

- 19958 Slanted Top with 10" Duct Collar
- 19959 Slanted Top with 12" Duct Collar
- 19947 Square with (2) 10" Duct Collars
- 19948 Square with (2) 12" Duct Collars

Miscellaneous:

- 703902 8' Power Cord 110-120V Only
- 603322 Gasket on Downstream Edge of Unit
- Magnehelic Gauge: Refer to the Back of this Section
- Static Control: Refer to the Back of this Section

Comments:

NOTE: Duct collar adapters #19950 & #19951 may be used without negating the UL listing. All other duct collars, air conditioning boxes, pilot lights, and adding other electrical components negates UL listing.

