

SAM Haz Loc

Got Hazardous Conditions? Use SAM Haz Loc Units

SAM Haz Loc (Hazardous Location) Units are ideal for supplying clean air to workstations or equipment in a location where ambient air is contaminated with chemical or other hazardous conditions.

Units include a 99.99% efficient HEPA filter, prefilter, spark resistant aluminum blower wheel and electrical parts with explosion proof ratings (AMCA Type B Construction).

Housings are fabricated from steel with a white powdercoat finish.

Units are available in 115 Volt (60 Hz), 208-230

Volt (50/60 Hz) and 277 (60 Hz), single phase and 208/460, 3 phase.

HEPA or ULPA 99.9995% eff. @ 0.12 micron final filters are protected with a white epoxy diamond pattern grille and are tested according to accepted procedures as described by the Institute of Environmental Sciences (IEST) and or ISO standards.

GS Style Units feature an anodized aluminum perforated grille with round holes hinged to open, permitting removal of the HEPA or ULPA filter without removing the unit from the ceiling.

Consult with one of our cleanroom experts in your area, or call the factory for more information.

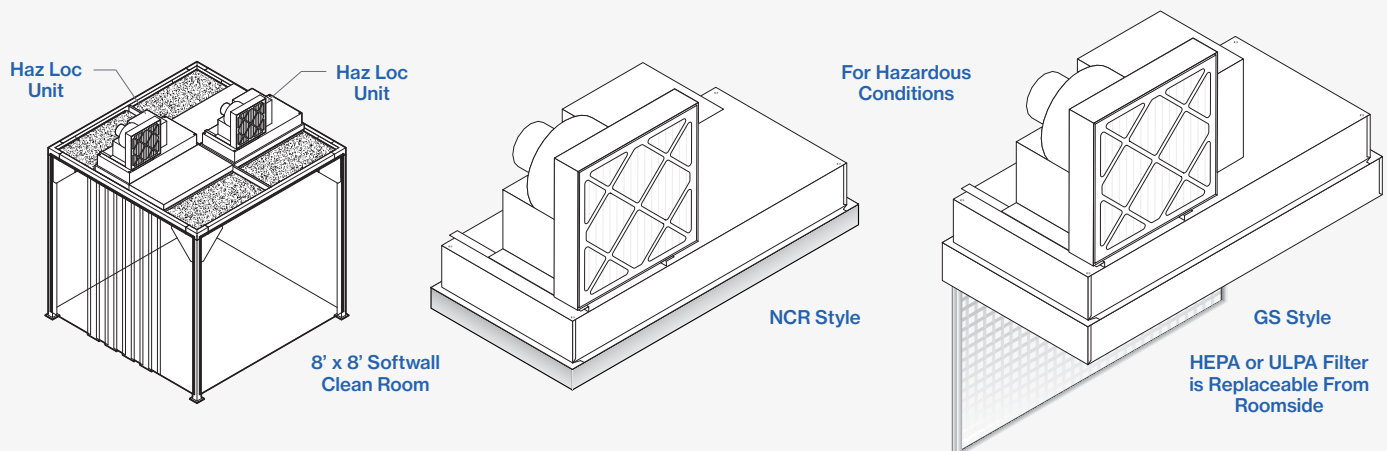

GS Style Filter Data

Size: 20-5/8" x 44-5/8" x 3" with anodized aluminum frame, upstream gel channel and diamond pattern white epoxy face screen. The HEPA is designed for 90 FPM average face velocity @ initial 0.47 w.g. and has a rated efficiency of 99.99% @ 0.3 micron or larger. An access port with removable plug is located in the center of the filter element face for introducing an upstream challenge or measuring static pressure.

NCR Style Filter Data

Size: 23-5/8" x 47-5/8" x 3" with exposed anodized aluminum frame and diamond pattern white epoxy

face screen. The HEPA Filter is designed for 90 FPM average face velocity @ initial 0.47 w.g. and has a rated efficiency of 99.99% @ 0.3 micron or larger.

Motor Data

SAM Haz Loc Units are equipped with an AMCA - B rated blower and Class 1 Group D, Class 2 Groups F & G motor.

CAUTION: It is always the responsibility of the customer to determine "Fitness-of-Use" of this product for the application. Clean Rooms International Inc. can not and will not make any recommendations for use of this product and will not be held liable or responsible for conditions and installations beyond our control. If you are unsure of your Hazardous Location requirement, it is advised that you contact your local Fire Marshall, OSHA, local Building Inspector or an Indoor Environmental test agency to help determine your needs.

Base Model (Ordering Information)

Mfg. Code	Model	Style	Size	Motor	Voltage	Hz
12950*	SAM 24 Haz Loc	NCR	2 x 4	Class 1 Group D, Class 2 Group F & G	115	60
12951	SAM 24 Haz Loc	NCR	2 x 4	Class 1 Group D, Class 2 Group F & G	208-230	60
12952*	SAM 24 Haz Loc	NCR	2 x 4	Class 1 Group D, Class 2 Group F & G	277	60
12953	SAM 24 Haz Loc	NCR	2 x 4	Class 1 Group D, Class 2 Group F & G	208/460	60
12954	SAM 24 Haz Loc GS	GS	2 x 4	Class 1 Group D, Class 2 Group F & G	115	60
12955	SAM 24 Haz Loc GS	GS	2 x 4	Class 1 Group D, Class 2 Group F & G	208/230	60
12956	SAM 24 Haz Loc GS	GS	2 x 4	Class 1 Group D, Class 2 Group F & G	277	60
12957	SAM 24 Haz Loc GS	GS	2 x 4	Class 1 Group D, Class 2 Group F & G	208-460	60

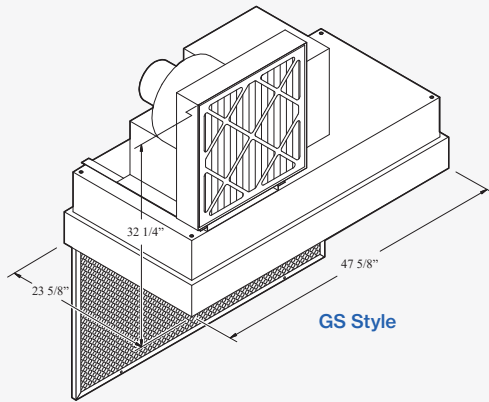

GS Style

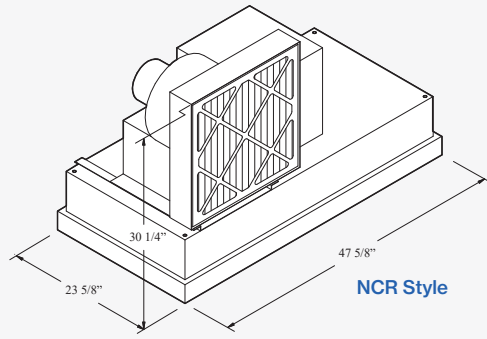

NCR Style

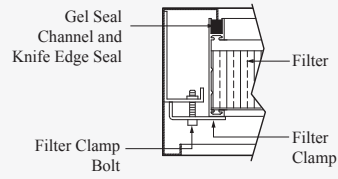

Filter Clamp Detail

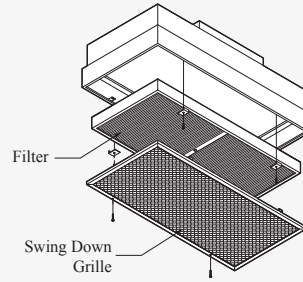

Exploded View

Replacement Filters

Mfg. Code	Description
302090	NCR Style HEPA Filter, 99.99% efficient @ 0.3 micron
302100	NCR Style ULPA Filter, 99.9995% efficient @ 0.12 micron
302200	GS Style HEPA Filter, 99.99% efficient @ 0.3 micron
302203	GS Style ULPA Filter, 99.9995% efficient @ 0.12 micron
302190	Prefilter 20" x 20" x 1", 30% ASHRAE efficient, pleated type

Note: Consult with the factory for horizontal flow applications