

SAM24 H.O. High Output

Delivers Up To 1000 CFM

SAM 24 H.O. Series Fan Filter Units are ideal for cleanroom applications with high ceilings.

SAM 24 H.O. Fan Filter Units are designed to deliver up to 1000 CFM, and include a 100mm 99.99% efficient HEPA filter, 2" prefilter, seismic clip suspension points, solid state variable speed control with RFI suppression, and a safety switch.

Housings are fabricated from steel with a white powdercoat finish and include seismic clip suspension points.

The energy efficient N310 motor blower is a low watt, backward curved impeller, single phase, permanent split capacitor type motor blower assembly with thermal overload protection. Units are available in 115 Volt (60 Hz), 208-230 Volt (50/60 Hz) and 277 (60 Hz).

The HEPA 100mm final filter is protected with a white epoxy diamond pattern grille and is tested according to accepted procedures as described by the Institute of Environmental Sciences (IEST) and or ISO standards.

GS units feature a polystyrene eggcrate grille in an anodized aluminum frame hinged to open, permitting removal of the HEPA or ULPA filter without removing the unit from the ceiling.

Popular options include an 8' power cord (115 Volt only), 99.9995% efficient ULPA grade final filter, and duct collar adapters. Refer to the back of this section for more options and accessories.

Consult with one of our cleanroom experts in your area, or call the factory for more information.

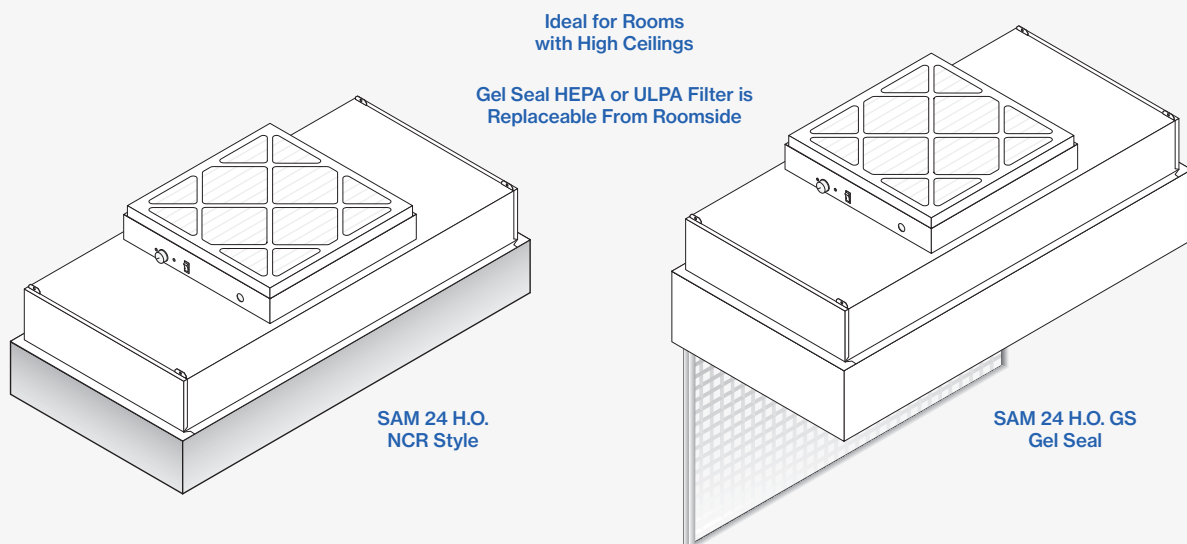

GS Style Filter Data

Size: 20-5/8" x 44-5/8" x 6" with anodized aluminum frame and diamond pattern white epoxy face screen. The HEPA Filter with 100mm media is designed for 145 FPM average face velocity @ initial 0.40 w.g. and has a rated efficiency of 99.99% @ 0.3 micron or larger. An access port with removable plug is located in the center of the filter element face and is used for introducing an upstream challenge or measuring static pressure.

NCR Style Filter Data

Size: 23-5/8" x 47-5/8" x 6" with exposed anodized aluminum frame and diamond pattern white epoxy

face screen. The HEPA Filter with 100mm media is designed for 145 FPM average face velocity @ initial 0.40 w.g. and has a rated efficiency of 99.99% @ 0.3 micron or larger.

Standard Equipment

Includes a N310 Low Watt motor, prefilter and a solid state variable speed control with RFI Suppression. A safety switch is provided for all voltages as listed below.

Options

ULPA Filter, Power Cord, Duct Collar Adaptors. More options are shown in the back of this section.

Replacement Filters

Mfg. Code	Description
302027	NCR Style HEPA Filter, 99.99% efficient @ 0.3 micron
302028	NCR Style ULPA Filter, 99.9995% efficient @ 0.12 micron
	GS Style HEPA Filter, 99.99% efficient @ 0.3 micron
-	GS Style ULPA Filter, 99.9995% efficient @ MPPS
302197	Prefilter 20 x 20 x 2, 30% ASHRAE efficient, pleated type

NOTE: Consult with the factory for horizontal flow applications

Base Model (Ordering Information)

Mfg. Code	Model	Style	Size	Motor	Voltage	Hz	Watts	FLA	Weight
12500	SAM 24 H.O.	NCR	2 x 4	N310	115	60	185	1.5	90 lbs. (40.8 kg.)
12501	SAM 24 H.O.	NCR	2 x 4	N310	208-230	50/60	172	0.75	90 lbs. (40.8 kg.)
12502	SAM 24 H.O.	NCR	2 x 4	N310	277	60	165	0.76	90 lbs. (40.8 kg.)
12503	SAM 24 H.O. GS	GS	2 x 4	N310	115	60	185	1.5	110 lbs. (49.9 kg.)
12504	SAM 24 H.O. GS	GS	2 x 4	N310	208-230	50/60	172	0.75	110 lbs. (49.9 kg.)
12506	SAM 24 H.O. GS	GS	2 x 4	N310	277	60	172	0.76	110 lbs. (49.9 kg.)

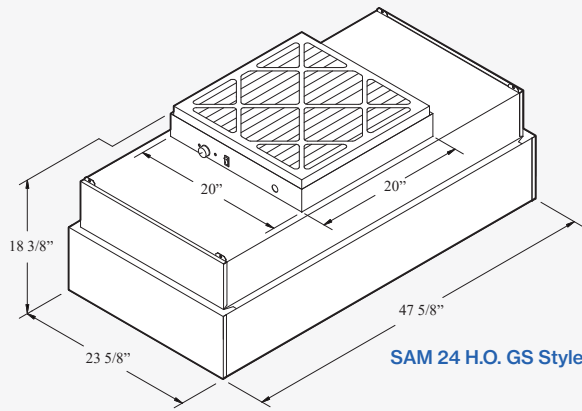

SAM 24 H.O. GS Style

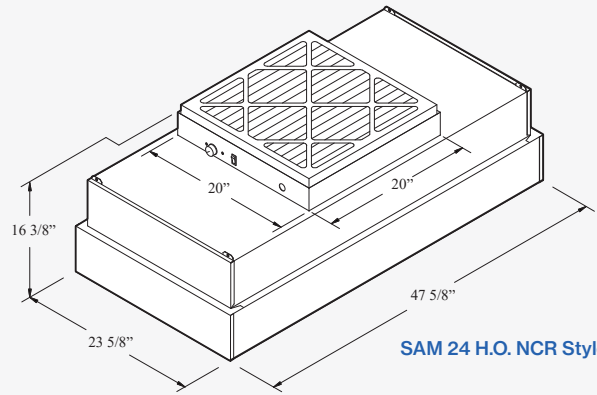

SAM 24 H.O. NCR Style

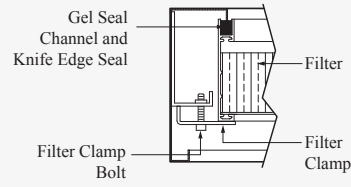

Filter Clamp Detail

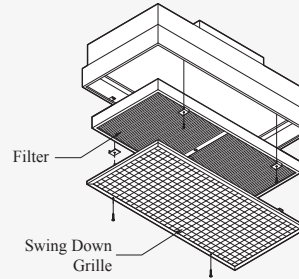

Exploded View

Notes:
