

SAM26 Series

SAM 26 Units are Ideal for Workstations and Special Applications

SAM 26 Fan Filter Units are ideal for supplying clean air to workstations, equipment or for special size ceiling spaces.

SAM 26 units include a 99.99% efficient HEPA filter, prefilter, seismic clip suspension points and solid state variable speed control with RFI suppression. Housings are fabricated from 20 gauge steel with white powdercoat finish.

SAM 26 units are equipped with two (2) N310 low watt backward curved impeller, 60 hz, single phase, permanent split capacitor type motor blower assemblies with thermal overload protection. Standard voltages are 115 volt (60 hz), 208-230 volt (50/60 hz) and 277 volt (60 hz).

Final filters are protected with a white epoxy diamond grille and are tested according to accepted procedures as described by the

Institute of Environmental Sciences (IEST) and/or ISO standards.

SAM 26 CRF units feature a polystyrene eggcrate grille in an anodized aluminum frame hinged to open, permitting removal of the HEPA or ULPA filter without removing the unit from the ceiling.

SAM 26 CRF LI units feature an integral 2-lamp high output light fixture located inside the filter housing below the final HEPA filter. The lights are automatically on when the unit is operating. The ballast is located on top of the unit for easy change out. An acrylic eggcrate grille in an anodized aluminum frame is hinged to open, permitting removal of the HEPA or ULPA filter and fluorescent lamp tubes.

Additional options and accessories are shown in the back of this section. Consult with one of our cleanroom experts in your area, or call the factory for more information.

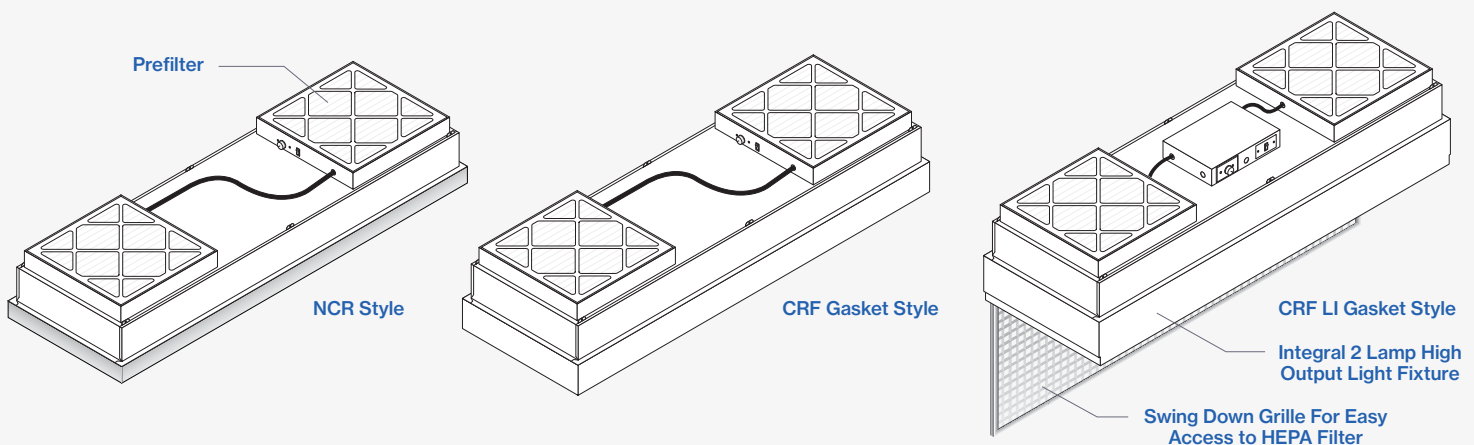

CRF Style Filter Data

The HEPA Filter is designed for 90 FPM average face velocity @ initial 0.47 w.g. and has a rated efficiency of 99.99% @ 0.3 micron or larger.

An anodized aluminum frame holds the 53mm media which is protected by a diamond pattern white epoxy coated steel grille. Final filters are replaceable from roomside.

Access Port

This port is located in the center of the filter element face and is used for introducing an upstream challenge or measuring static pressure.

Ordering Information

Mfg. Code	Model	Size	Voltage	Motor	Hz	Watts	Weight
12603	SAM 26 CRF	2 x 6	115	N310	60	370	140 lbs. (64 kg.)
12604	SAM 26 CRF	2 x 6	208/230	N310	50/60	340	140 lbs. (64 kg.)
12605	SAM 26 CRF	2 x 6	277	N310	60	340	140 lbs. (64 kg.)
12606	SAM 26 CRF w/2-Lamps	2 x 6	115	N310	60	370	150 lbs. (68 kg.)
12607	SAM 26 CRF w/2-Lamps	2 x 6	208/230	N310	50/60	340	150 lbs. (68 kg.)
12608	SAM 26 CRF w/2-Lamps	2 x 6	277	N310	60	340	150 lbs. (68 kg.)

Note: Consult with the factory for horizontal flow applications

Replacement Filters

Mfg. Code	Description
302130	CRF Style HEPA Filter, 99.99% efficient @ 0.3 micron
302131	CRF Style ULPA Filter, 99.9995% efficient @ 0.12 micron
302190	Prefilter 20" x 20" x 1", 30% ASHRAE efficient, pleated type

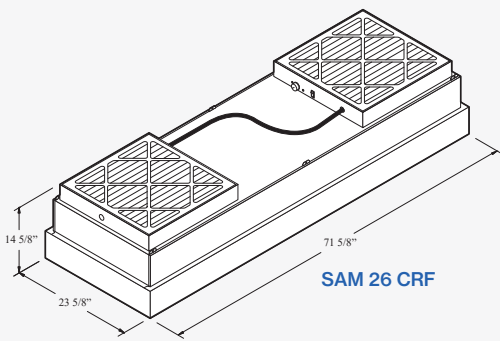

SAM 26 CRF

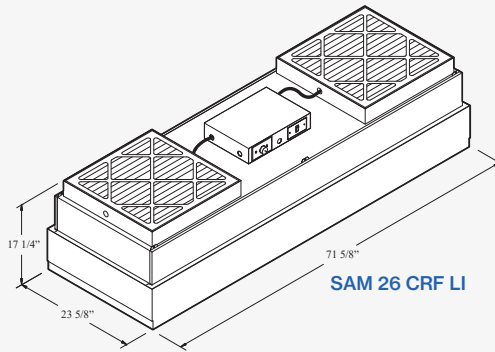

SAM 26 CRF LI

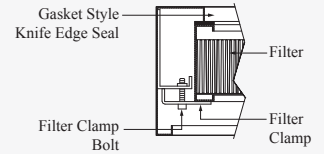

Filter Clamp Detail: CRF

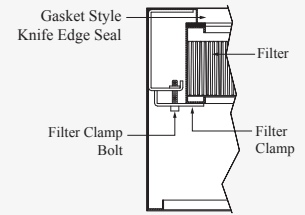

Filter Clamp Detail: CRF/LI

NCR Style Filter Data

The HEPA Filters are designed for 90 FPM average face velocity @ initial 0.47 w.g. and have a rated efficiency of 99.99% @ 0.3 micron or larger. An anodized aluminum frame holds the 53mm media

which is protected by a diamond pattern white epoxy coated steel grille.

Final filters can be replaced by removing unit from ceiling or workstation, placing on a bench, removing and replacing the filter and re-installing complete unit.

Ordering Information

Mfg. Code	Model	Size	Voltage	Motor	Hz	Watts	Weight
12600	SAM 26 MS	2 x 6	115	N310	60	370	118 lbs. (54 kg.)
12604	SAM 26 MS	2 x 6	208/230	N310	50/60	340	118 lbs. (54 kg.)
12605	SAM 26 MS	2 x 6	277	N310	60	340	118 lbs. (54 kg.)

Note: Consult with the factory for horizontal flow applications

Replacement Filters

Manufacturing Code	Description
302120	NCR Style HEPA Filter, 99.99% efficient @ 0.3 micron
302125	NCR Style ULPA Filter, 99.9995% efficient @ 0.12 micron
302190	Prefilter 20" x 20" x 1", 30% ASHRAE efficient, pleated type

Switch Detail

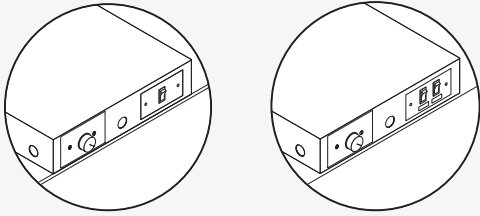

Electrical Switches Configuration for all SAM 26 Models May Vary Due to Application Requirements

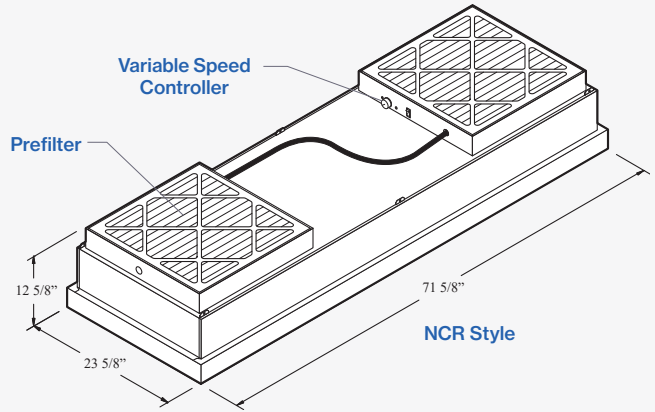

6' Horizontal Flow Clean Bench

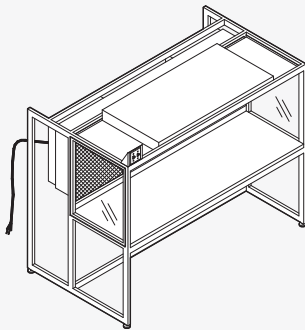

6' Vertical Flow Clean Bench

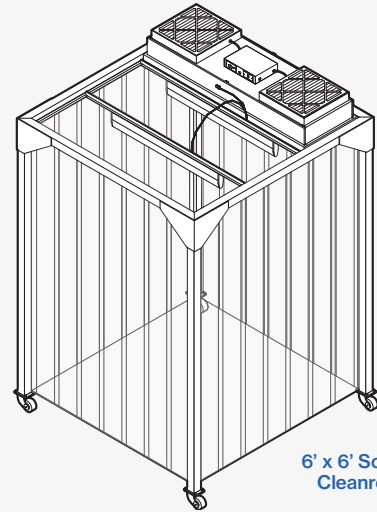
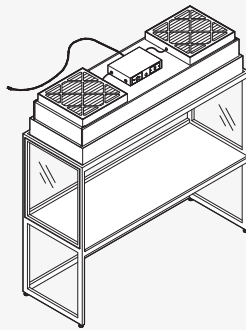

6' x 6' Softwall Cleanroom

Popular Applications for SAM 26 Units

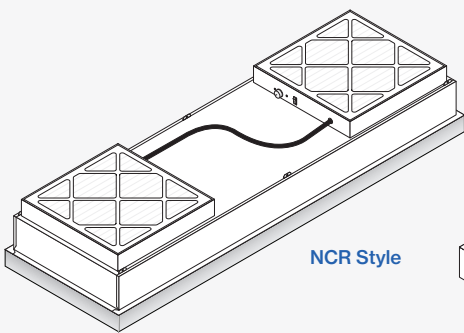

NCR Style

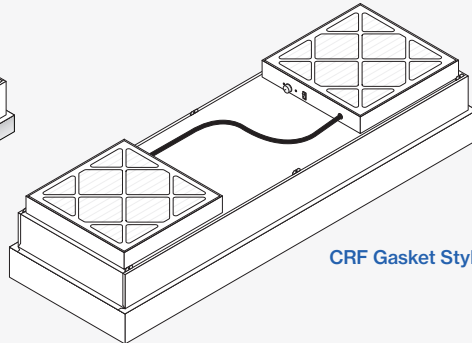

CRF Gasket Style

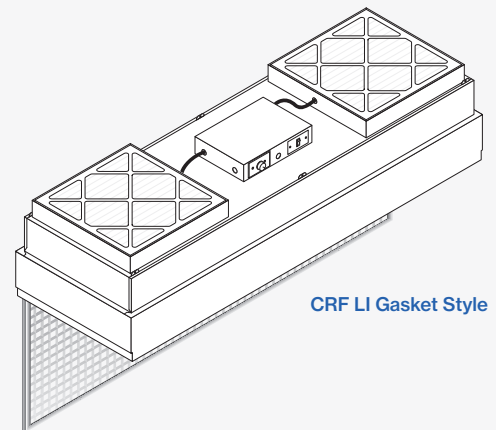

CRF LI Gasket Style

Notes:
