

Table Top Work Stations

General Information

A self contained SAM Fan Filter Unit provides Class 100 HEPA filtered air in a vertical flow pattern within the workspace.

Electrical

Standard voltage is 115 volts with other voltage options shown on a following page. An On/Off switch is installed on the SAM unit. All 115 volt models are equipped with a 8 foot power cord and 3 - prong plug. Other voltages require electrical connection to the power source by a qualified electrician.

Final Filter

HEPA filters are 99.99% efficient @ 0.3 micron or larger with anodized aluminum frame. ULPA grade

filters are 99.9995% efficient @ 0.12 micron, and are available as an option.

Prefilter

A pleated type, disposable prefilter rated at 30% ASHRAE efficiency is standard.

Speed Control

A solid state variable speed control is mounted on the SAM unit.

Grille

Table Top Workstations with lights have an acrylic grille inserted in an anodized aluminum frame which is hinged to open. This permits access to the fluorescent light tubes and removal of the HEPA filter without removing the SAM unit from

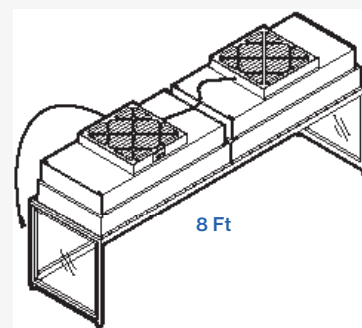
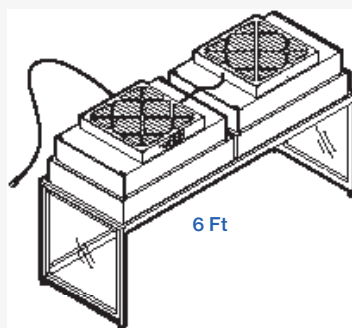
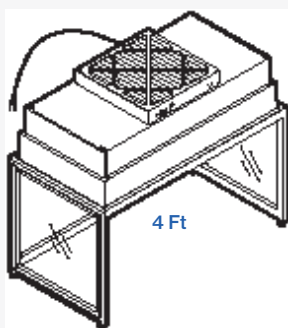
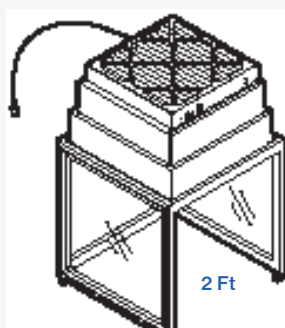

the frame. Workstations without lights have a painted white epoxy diamond pattern grille.

Construction

Table Top Workstation frames are white painted steel tubing with clear acrylic side and back panels and adjustable leg levelers. Workstations are designed to be placed on a table or other suitable work surface.

Lighting

All 2', 4', & 8' models with lights are equipped with a 4-lamp light fixture, 120 volt, 60 hz with T8, 32W electronic ballast. The 6' models are equipped with a 2-lamp fixture, 120V, 60 hz., T12

ballast and two (2) high output lamps. Fluorescent light tubes are not furnished with the units because of potential breakage during shipment.

Shipping

Workstations are partially assembled with the SAM unit packaged separately for safe shipping. The self contained SAM unit is easily installed in the frame on site with no special tools required.

See a following page for options and ordering information.

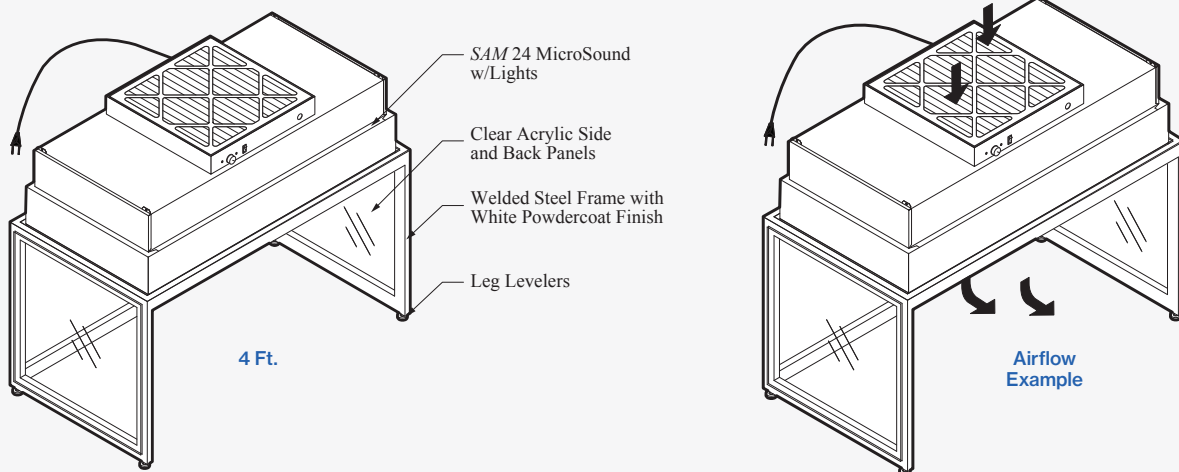

Ordering Information Table Top Flow Work Stations with Lights

Model No.	Voltage	Nominal	Overall Dimensions	Opening Size	Weight
13100	115V	2 Ft.	26"L x 26"D x 47.25"H	24"L x 30"H	175 lbs.
13101	115V	4 Ft.	50"L x 26"D x 47.25"H	48"L x 30"H	250 lbs.
13102	115V	6 Ft.	74"L x 26"D x 47.25"H	72"L x 30"H	300 lbs.
13103	115V	8 Ft.	98"L x 26"D x 47.25"H	96"L x 30"H	325 lbs.

NOTE: Fluorescent light tubes not included

Options

208-230V, 50/60 hz motor	Custom sizes and designs
277V, 60 hz motor	ULPA Filter 99.9995% efficiency @ 0.12 micron or larger

Refer to following pages for more options