

# C-Frame Work Stations

## General Information

C-Frame Workstations offer increased versatility and save space by eliminating the frames needed for front legs. The frame is cantilevered for placing over any work bench, table or wet process work station without taking up valuable floor space and obstructing adjacent work areas. A SAM Fan Filter Unit provides HEPA filtered air over the workspace.

## Electrical

Standard voltage is 115 volts with other voltage options shown on a following page. An On/Off switch is installed in a 2"x 4" junction box mounted on the SAM unit. All 115 volt models are equipped with a 8 foot power cord and 3 - prong plug. Other

voltages require electrical connection to the power source by a qualified electrician.

## Final Filter

HEPA filters are 99.99% efficient @ 0.3 micron or larger with anodized aluminum frame. ULPA grade filters are 99.9995% efficient @ 0.12 micron, and are available as an option.

## Prefilter

A pleated type, disposable prefilter rated at 30% ASHRAE efficiency is standard.

## Speed Control

A solid state variable speed control is mounted on the SAM unit.

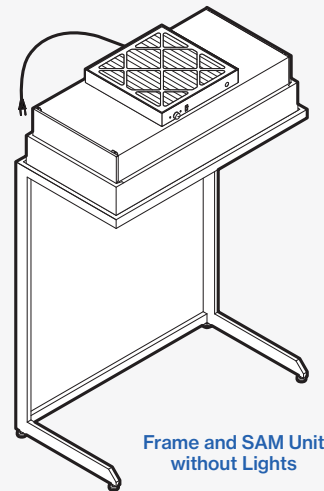
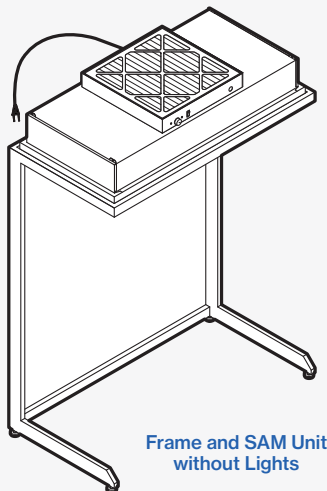
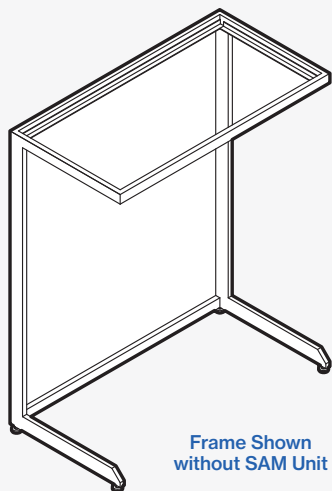

## Grille

Table Top Workstations with lights have an acrylic grille inserted in an anodized aluminum frame which is hinged to open. This permits access to the fluorescent light tubes and removal of the HEPA filter without removing the SAM unit from the frame. Workstations without lights have a painted white epoxy diamond pattern grille.

## Construction

C-Frame Workstations with lights have an acrylic grille inserted in an anodized aluminum frame which is hinged to open. This permits access to the fluorescent light tubes and removal of the HEPA filter without removing the SAM unit from

the frame. Workstations without lights have a painted white epoxy diamond pattern grille.

## Lighting

C-Frame Workstations with lights are equipped with a 4-lamp light fixture, 120 volt, 60 hz with T8, 32W electronic ballast. Fluorescent light tubes are not furnished with the units because of potential breakage during shipment.

## Shipping

C-Frame Workstations are partially assembled with the SAM unit packaged separately for safe shipping. The self contained SAM unit is easily installed in the frame on site with no special tools required.

See a following page for options and ordering information.

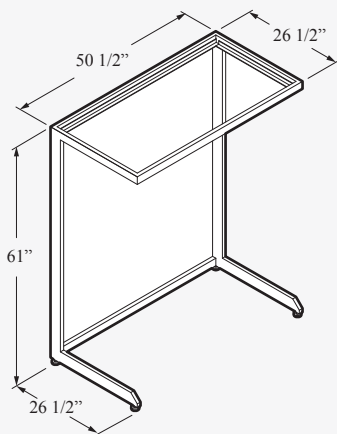

**Frame Shown  
without SAM Unit**

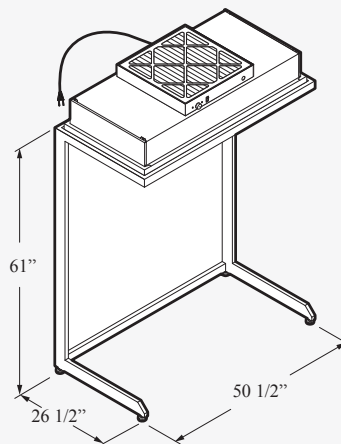

**Frame and SAM  
Unit without Lights**

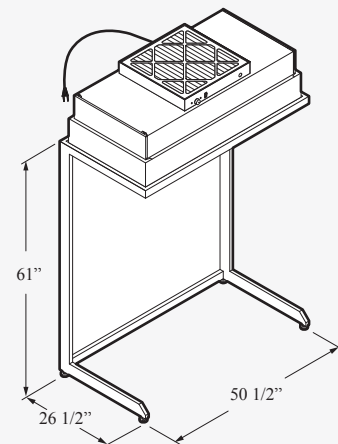

**Frame and SAM  
Unit with Lights**

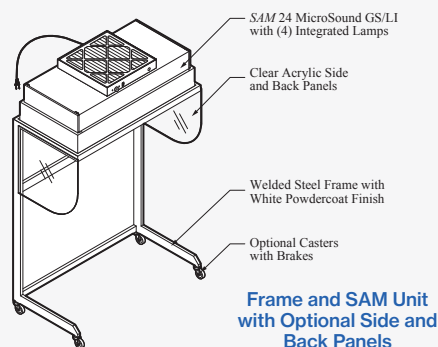

**Frame and SAM Unit  
with Optional Side and  
Back Panels**

## Options

Part No.	Description of Options Above
805083	Casters, 3" with Brakes, (4) required
905234	Side Panels, 1/4" Clear Acrylic, 24" H x 26.5" D, (2) required
905235	Back Panels, 1/4" Clear Acrylic, 24" H, (1) required

Consult the factory for more information

## Additional Options

208-230V, 50/60 hz motor	Static Control Package
277V, 60 hz motor	Duct Collar Adapter, 10" or 12" diameter
ULPA Filter 99.9995% efficiency @ 0.12 micron or larger	Custom sizes and designs

Consult the factory for more information

## Ordering Information C-Frame Work Station without Lights

Model No.	Nominal	Overall Dimensions	Weight
13400	4 Ft.	50.5"L x 26.5"D x 73"H	165 lbs.

NOTE: Includes Frame and SAM 24 MicroSound

## Ordering Information C-Frame Work Station with Lights (Fluorescent light tubes not included)

Model No.	Nominal	Overall Dimensions	Weight
13401	4 Ft.	50.5"L x 26.5"D x 78"H	190 lbs.

NOTE: Includes Frame and SAM 24 MicroSound CRF/LI, 115V