

Air Showers

HEPA Filtered Walk-Through Air Shower Chamber Removes Particulate Contamination

Minimum Velocity of 5000FPM

Air Showers are designed to supply ISO Class 5 (Class 100) airflow while removing particulate contamination from personnel entering a cleanroom. An individual can stand or walk through the chamber and be scrubbed by pressurized air from nozzles at a minimum velocity of 5000 FPM.

HEPA Filters

HEPA filtered air flows through wall mounted nozzles and contaminated air is forced through secondary filters located near the floor.

Lighting

Fluorescent lighting is provided in the ceiling.

Voltage

Voltage options are 208-230, 50 or 60 Hz and 440/480 volts, 3 phase, 60 Hz.



Typical Walk-Through Chamber

Features: Microprocessor
Control Panel

Material

Air Showers are made from composition board covered with white high pressure laminate on both inside and outside surfaces.

Doors are made of high quality anodized aluminum frame with 1/4 inch clear insert and push/pull hardware. The interlock system allows only one door at a time to be open and releases if the power fails.

An optional painted steel finish is available.

Shipping

Air Showers are shipped in wooden crates for on-site assembly.

Typical Configurations and Components

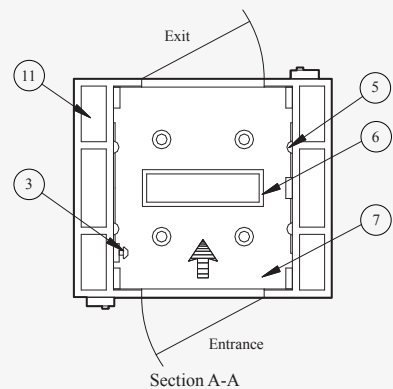
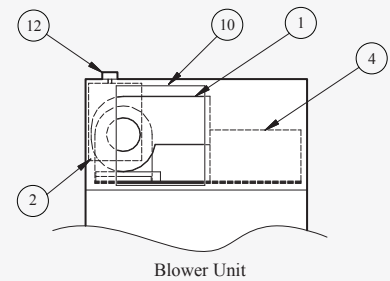
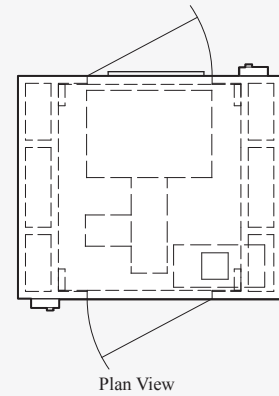
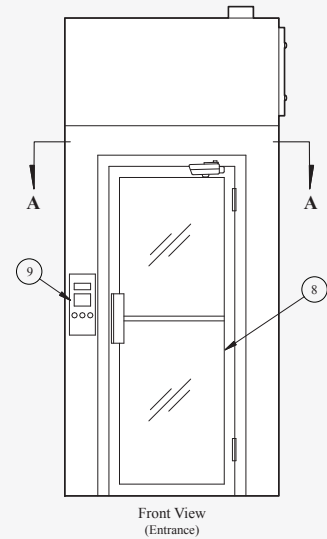

Typical Components

No.	Description
1	Motor/Blower assembly
2	Power control box
3	Emergency release button
4	HEPA Filter 99.97% effective on .3 micron particles
5	Adjustable nozzles
6	Fluorescent light fixture
7	Automatic activated floor switch
8	Anodized aluminum doors with plexiglas windows
9	Microprocessor control panel, On/Off Lights, Reset and Alarm
10	Access panels for easy maintenance
11	Electric interlocking chamber
12	Single connection junction box

Consult with factory for more information